

A large, abstract graphic of a solar panel grid pattern, rendered in a dark blue/purple color scheme, forming a large 'C' shape that frames the central text.

Manual wave single

Manual

Wave Single

Table of Contents

Introduction	3
About this document	3
Other relevant documents	3
Symbols used in this manual	3
Warranty and liability	3
Warranty	3
Liability	3
Product information	4
Intended use	4
Specifications	4
Solar panel flange dimensions	5
Requirements for the work environment	5
System and application	6
1. Components	6
Safety	7
1. Personal protective equipment	7
2. Safety warnings and regulations	7
Installation	8
1. Preparation	8
2. Place the units	11
3. Connect units with stabilizers	14
4. Place permanent ballast	16
5. Mounting the first solar panel	23
6. Mounting the following solar panels	25
7. Placing Rear Deflectors	27
Annexes	30
A. Cable management	30
B. Grounding and equipotential bonding	31
C. Removal and recycling	32

Introduction

About this document

This manual covers the installation instructions for the PanelClaw Wave mounting system for solar panels on flat roofs with roofing materials made of concrete, bitumen, EPDM, PVC and TPO. For other roof materials, please contact your supplier.

The mounting system is suitable for mounting solar panels in a single landscape orientation.

These instructions are addressed at qualified technical personnel.

You can download the latest version of this manual from www.panelclaw.eu.

Other relevant documents



When installing the PanelClaw Wave mounting system, you will need the following documents in addition to this manual:

- The project plan, which you can create in the calculator at <https://calculator.panelclaw.eu>.
- The installation manuals for the solar panels, inverters and any other components.

During the installation of the mounting system, it is important to adhere to the installation manual, the installation manual of the components, and the accompanying standards to prevent accidents. Pay special attention to (local) standards, regulations and legislation (among others):

- Local Building Regulations (latest version)
- Health and Safety at Work etc Act 1974
- Health and Safety in Roof work - HSE
- Eurocodes 0 (EN 1990 - Structural Design)
- Eurocodes 1 (EN 1991 - (Influences on structures)
- HD-IEC 60364 series - Electrical installations for low voltage
- EN-IEC 62305-2 - Protection lightning - Risk Management
- MIS 3002 - The solar PV standard
- MCS012 - Product Certification Scheme Requirements: Pitched Roof Installation Kits

Symbols used in this manual

	Warning!	Failure to follow this instruction could result in serious injury or major damage to the product.
	Caution!	Failure to follow this instruction could result in personal injury or damage to the product.
	Note	Emphasises an instruction.

Warranty and liability

Warranty

PanelClaw extends a 20 year product warranty. The warranty is subject to the warranty terms and general terms & conditions of PanelClaw. These can be found on the website www.panelclaw.eu.

Liability

PanelClaw accepts no liability for damage or injury caused by the failure to comply (strictly) with the safety guidelines and instructions in this manual, or by negligence during installation of the product and the accessories listed in this document.



PanelClaw reserves the right to change this document without notice.

Product information

Intended use

The PanelClaw Wave Single mounting system is intended for mounting solar panels on flat roofs. With this mounting system you can install solar panels with the long side at the bottom (landscape). The mounting system is intended to be installed in a single arrangement.

Specifications

Orientation of solar panels	Landscape
Frame height of solar panel	29 - 50mm
Maximum dimensions of solar panels	Length: 1550 mm - 2500 mm Width: 1070 mm - 1150 mm
Maximum field size	40 × 40 m per segment
Roof material	Concrete Bitumen EPDM PVC TPO
Roof pitch	0 - 5°  If your roof slope is > 5°, please contact your supplier.
Maximum roof height	 Subject to Eurocode guidelines and national additions. Use the calculator to calculate the possibilities of your project.
Edge zone	 Calculate the edge zone with the calculator. The distance of the solar panels to the edge of the roof should be approximately 1/5 of the height of the building with a minimum distance of 30 cm, due to highly turbulent wind currents in this zone. No solar panels may be installed in this zone, whether entirely or in part.

Solar panel flange dimensions

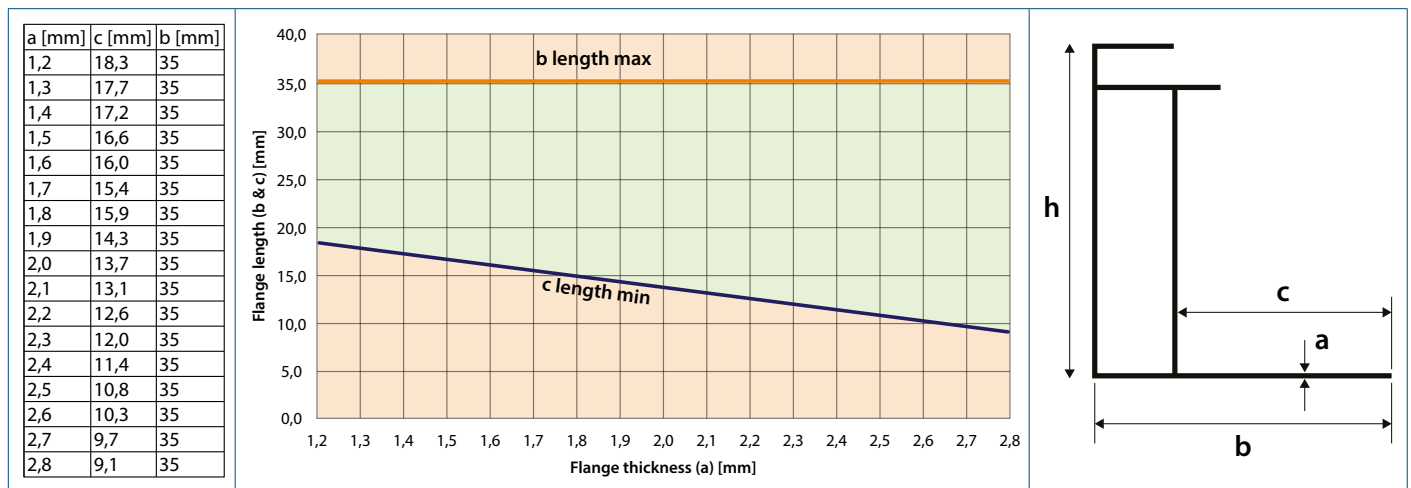

! Enter the data in the calculator, so you are sure of choosing the right system for the terrain category, snow loads and wind zone that applies to your project.

i If your project has different specifications than these, please contact PanelClaw.

Requirements for the work environment

<input type="checkbox"/>	The roof is in good condition.
<input type="checkbox"/>	The roof construction has sufficient bearing capacity to support the installation, taking into account wind and snow loads.

System and application

1. Components

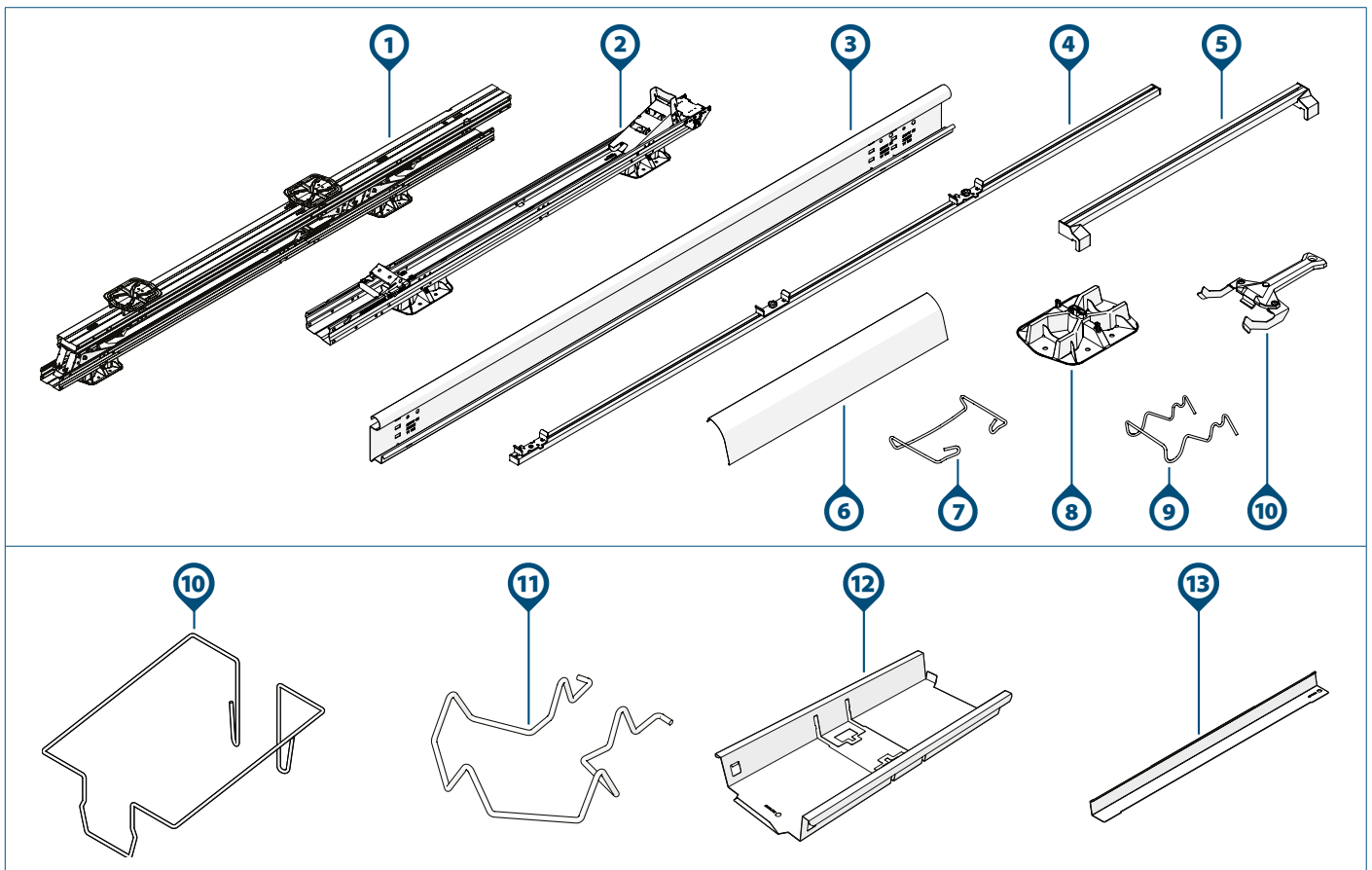



Component	Article number	Component	Article number
1) Wave Single Unit 3P SR2	1009160	7) Wave Single Rear Deflector Clip	1009170
2) Wave Single Unit 1P SR2	1009161	8) Wave Base Plate	1009120
3) a. Wave Stabilizer 2900	1009110	9) Wave Cable Bracket - Stabilizer	1009124
b. Wave Stabilizer 3530	1009111	10) Wave Module Unlock Tool	1009142
c. Wave Stabilizer 4000	1009114	11) Wave Ballast Bracket	1009123
d. Wave Stabilizer 4350	1009115	12) Wave Ballast Bracket Perimeter	1009126
4) Wave Measuring Bar 2500mm	1009143	13) Wave Ballast Tray	1009129
5) Wave Spacer Tool	1009144	14) Wave Ballast Tray Extender	1009130
6) a. Wave Single Rear Deflector1525	1009171		
b. Wave Single Rear Deflector1700	1009172		
c. Wave Single Rear Deflector1875	1009173		
d. Wave Single Rear Deflector2075	1009174		
e. Wave Single Rear Deflector2225	1009175		

i Check that the correct components are present in the required numbers according to the project plan generated by the calculator.

For situations where a PV system needs to be connected to the lightning collection system, see Appendix Lightning protection for more information.



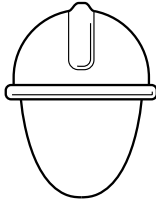

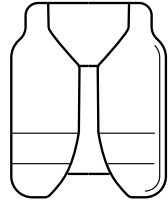



Safety

1. Personal protective equipment



						
Hearing protection	Safety helmet	Safety glasses	Face masks	Safety gloves	Safety clothing	Safety shoes

2. Safety warnings and regulations

Warning!



-  Installation work should always be carried out by at least two skilled people.
-  Do not use components from other mounting systems.
-  Do not leave out parts.
-  Always work according to the current regulations for working on roofs.
-  Do not perform the installation in strong winds, or when the roof is slippery or wet.
-  Always work on the roof with fall protection and, if necessary, with safety nets and edge protection.
-  Never stand on or in the gutter.
-  Always use a lifting aid or hoisting device when moving heavy equipment.
-  Always place ladders on a strong, stable surface.



Caution!

-  Walk as little as possible on the roof. Use an aerial platform, ladder or other solution.
-  Never walk on the system or on the solar panels.
-  PanelClaw is in no way responsible for the installation and/or connection of lightning protection on the roof. Get expert advice from your specialist and ensure that a safe installation can be guaranteed according to EN-IEC 62305 and HD-IEC 60364.

Installation

1. Preparation

1 Inspect the roof.	
	The roof is in good condition.
	The roof construction has sufficient bearing capacity to support the installation, taking into account wind and snow loads.

2 Check the project plan and components.	
	Check the project plan. Is there no project plan? Then create one in the online calculator before starting installation.
	Check that all components are present (page 5).

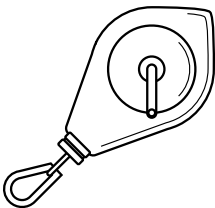
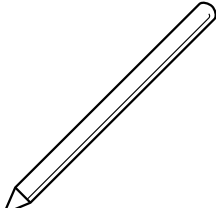
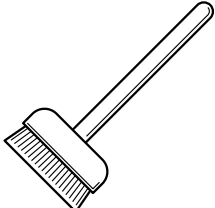
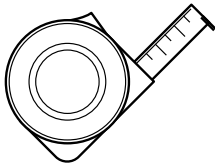
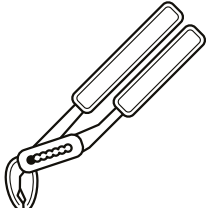
3 Make sure all the required tools are at hand.				
				
Chalkline tool	Marker or chalk	Broom	Tape measure	Water pump pliers

4 Measure the length of the solar panels and check the corresponding length of the rear deflector.	
1550 - 1765mm	Wave Single Rear Deflector 1525
1765 - 1920mm	Wave Single Rear Deflector 1700
1920 - 2105mm	Wave Single Rear Deflector 1875
2105 - 2300mm	Wave Single Rear Deflector 2075
2300 - 2500mm	Wave Single Rear Deflector 2225

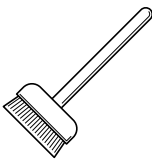
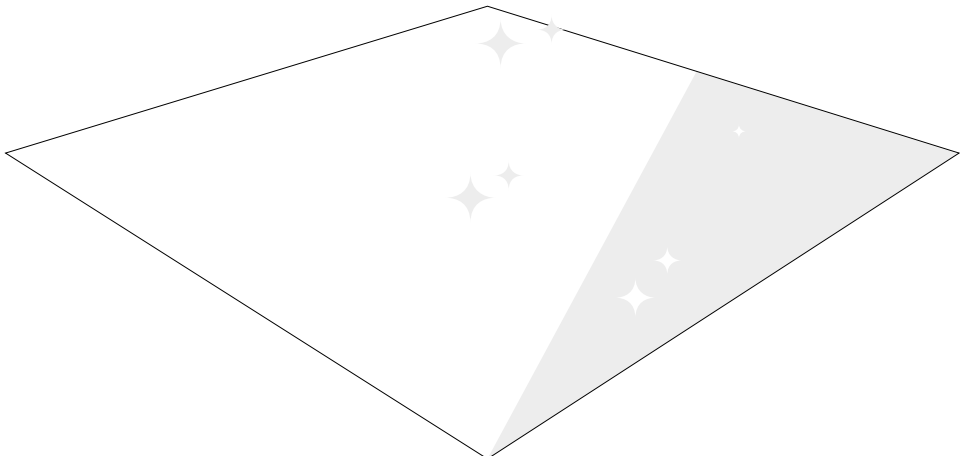
5 Clean and tidy the roof.	
	

6 Draw the lines of the field and make note of the orientation of the north arrow.

i Use the 3-4-5 rule to make sure the angle between your perpendicular lines is 90 degrees.

i Consult the project plan to determine the position of the units for your project.

i Take the starting point of the installation from the project plan.

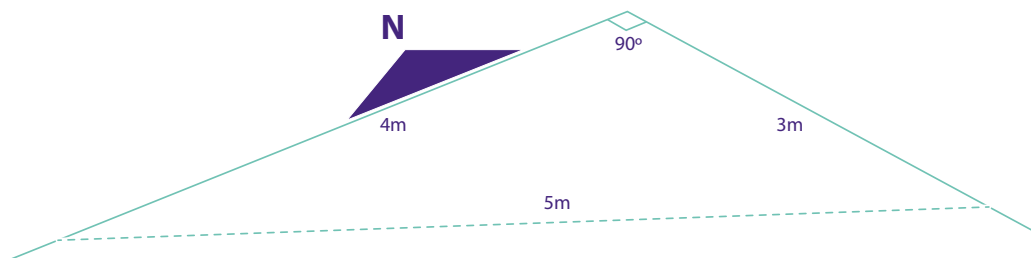
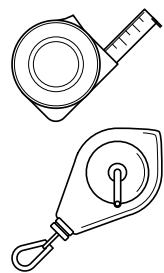

7 Mark the position of the first Wave unit.

i Be mindful of the no-go zone. Consult the project plan to determine the position of the first unit.

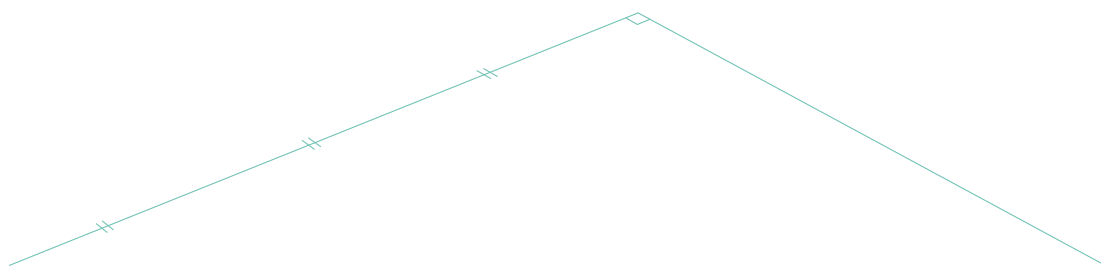
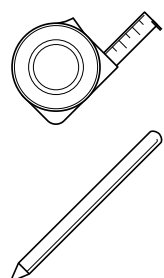

8 Align the "B"-marked side of the first and third bracket of the measuring bar to the corners of a solar panel.

i Alternatively, use a tape measure and check the project plan for the specified distance "B".

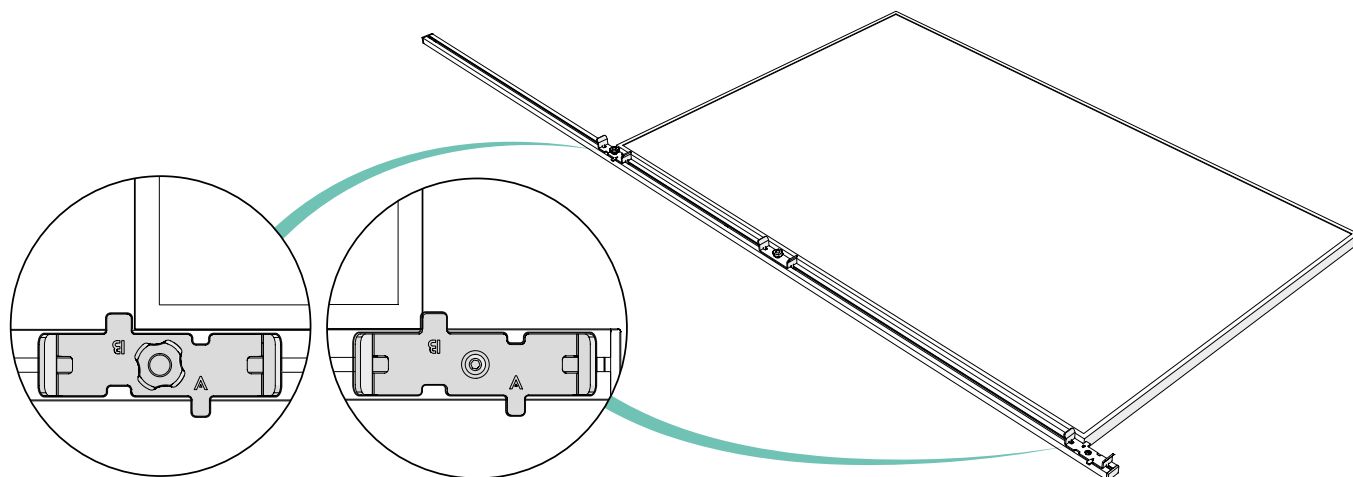

9 Adjust the centre bracket to the distance "A" as specified in the project plan.

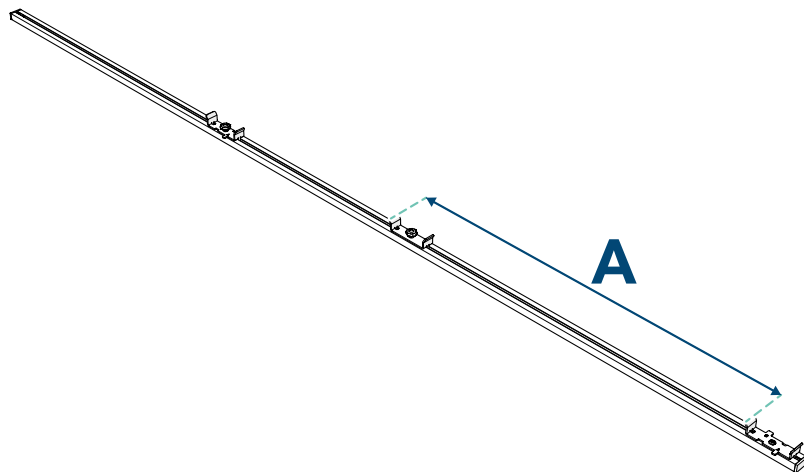

10 Duplicate the distances "A" and "B" for all measuring bars.

i Tip: often, six measuring bars are used to easily align and install the units and the solar panels.

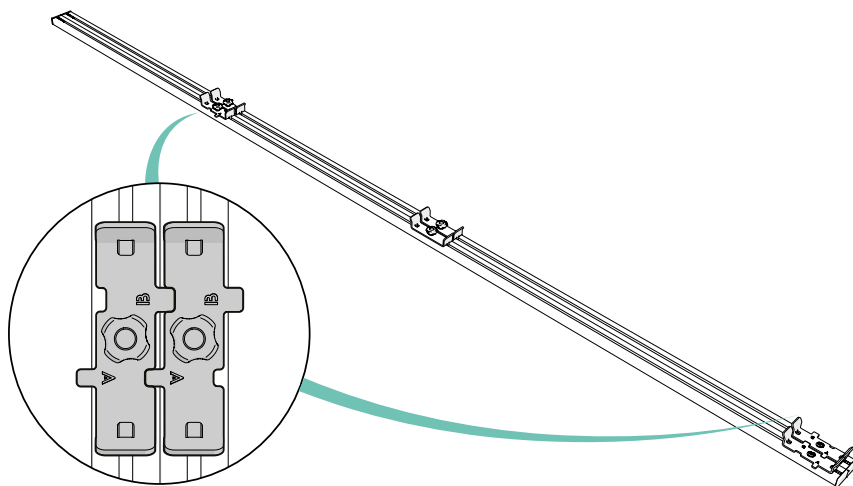

2. Place the units

1 Place the first unit on the roof and align the unit with the marked lines.

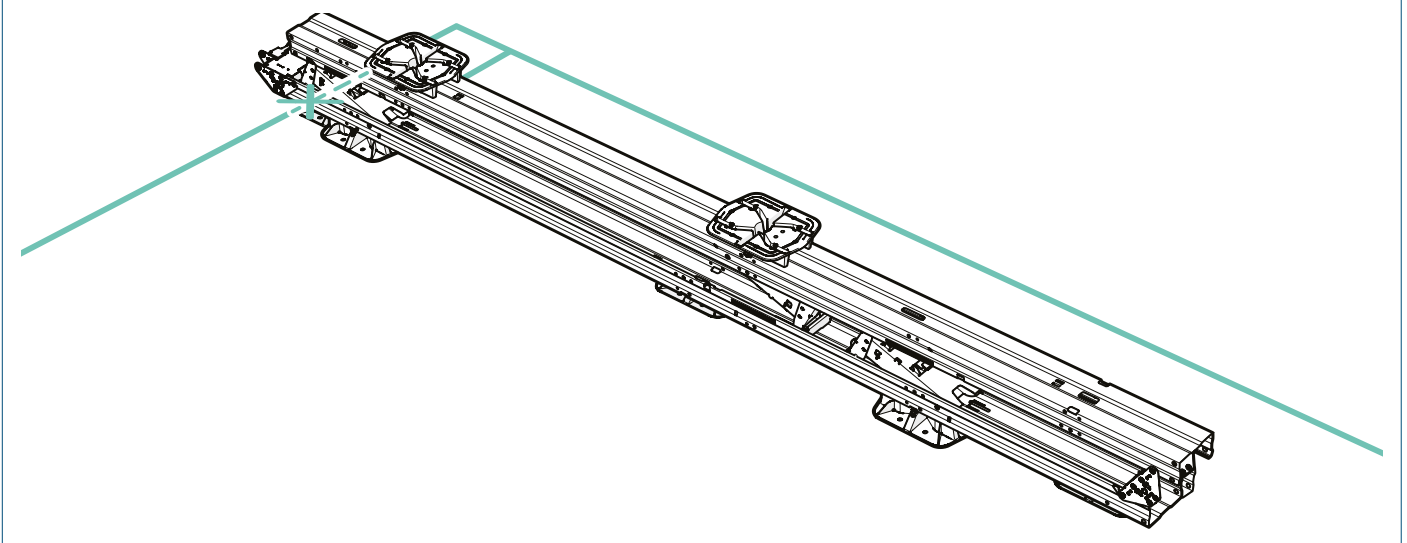

2 Fold open the unit. (only for 3P units)

 Lift the unit at the coupler until it clicks into place on both sides.

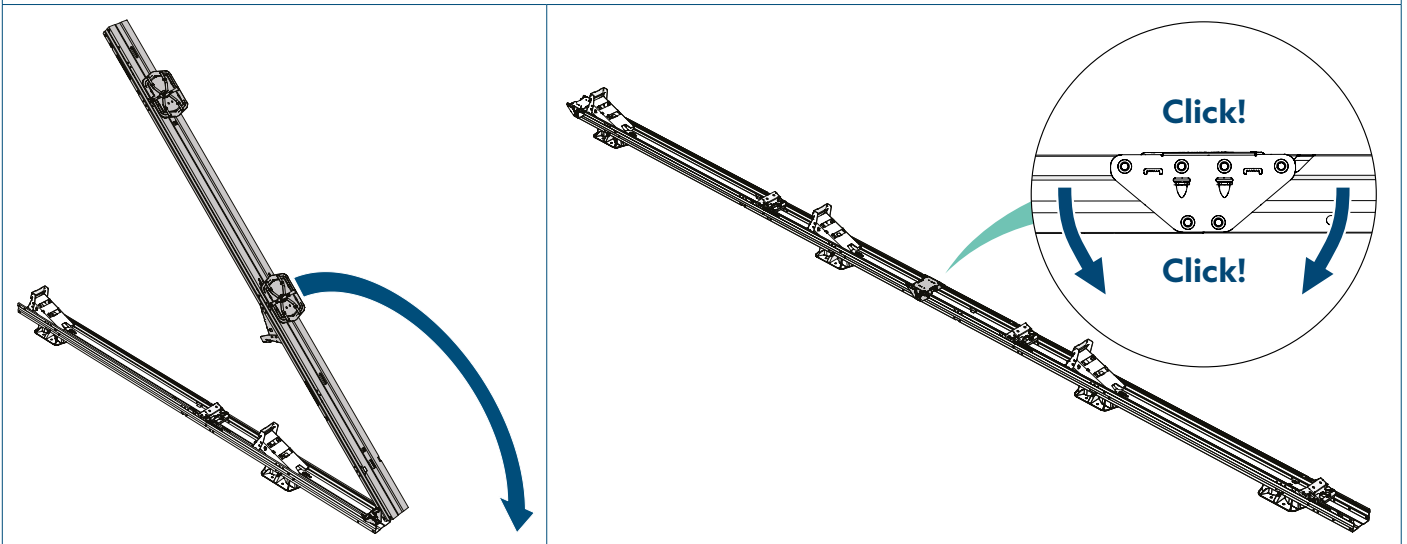

3 Tilt up the high base until it clicks into upright position.

 While doing this, squeeze the unit to ensure that the hooks of the high base hook into the groove of the unit.

 Check that the unit is still aligned with the perpendicular lines.

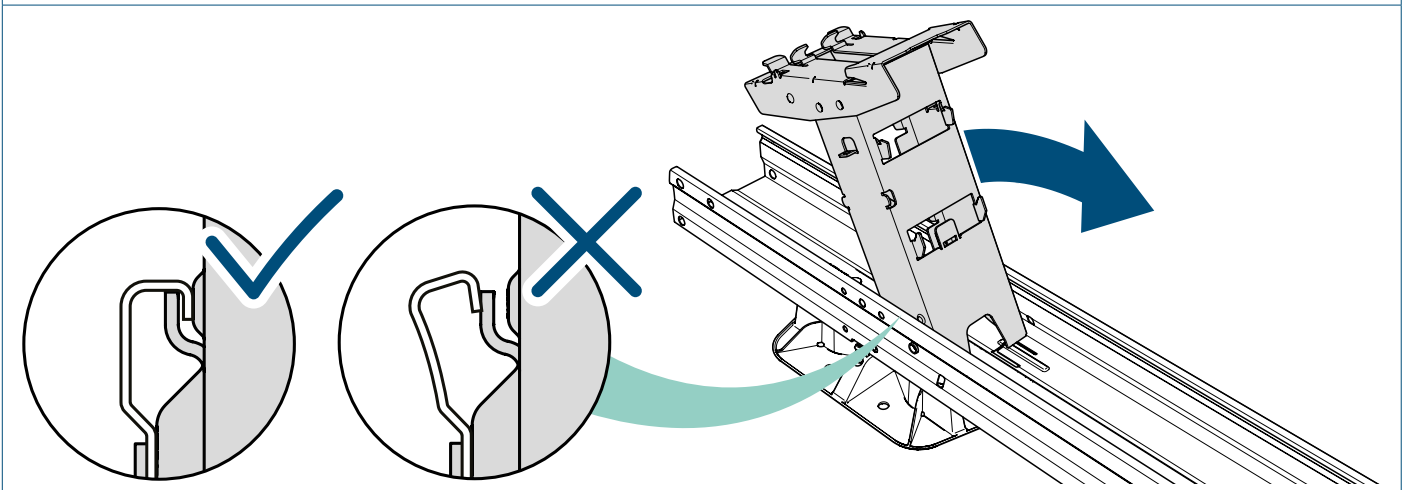

4 Place (temporary) ballast to prevent the unit from accidentally moving.

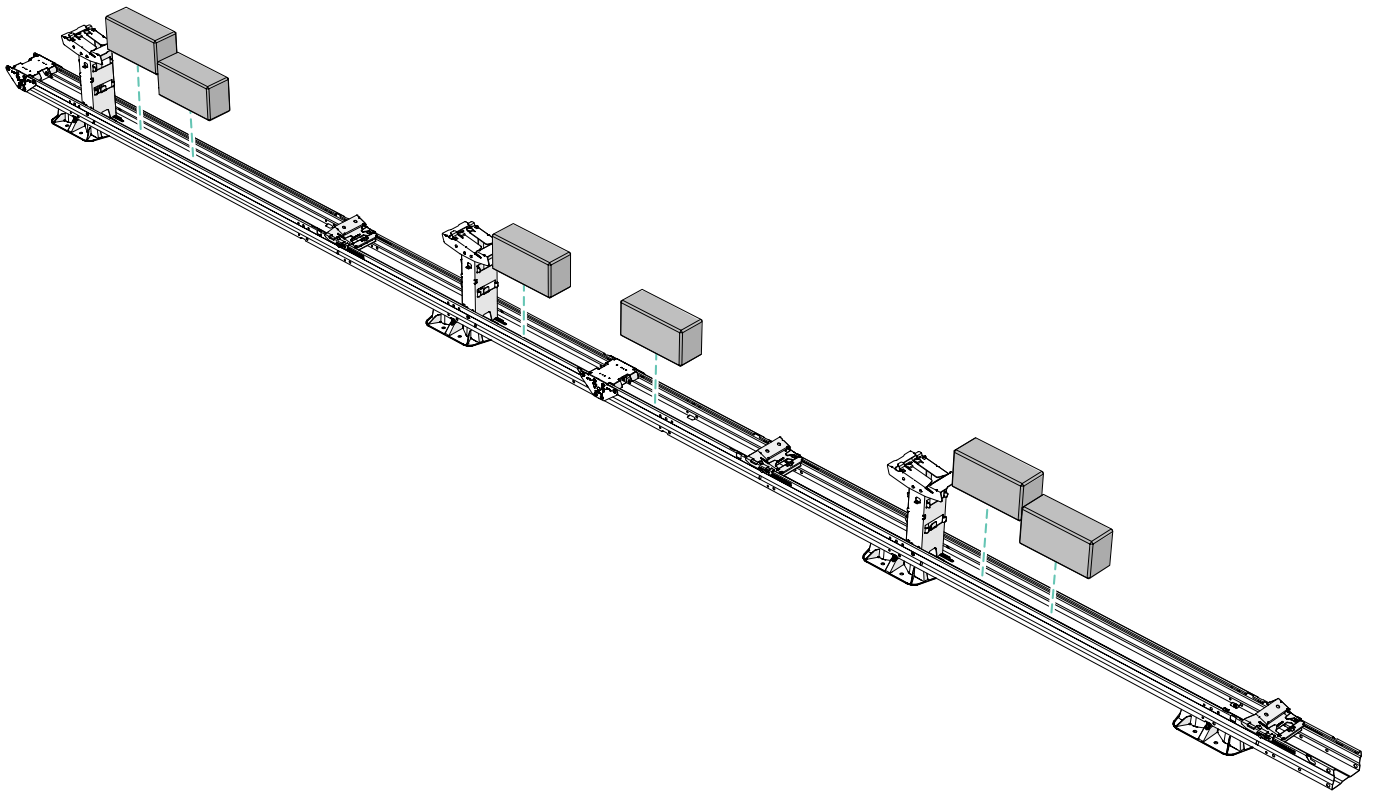

5 Place the next two units on the roof.

! For installation on a location with high snow loads: Consult the project plan to determine if an additional third unit needs to be placed in the center of each solar panel. This helps prevent damage caused by excessive snow load.

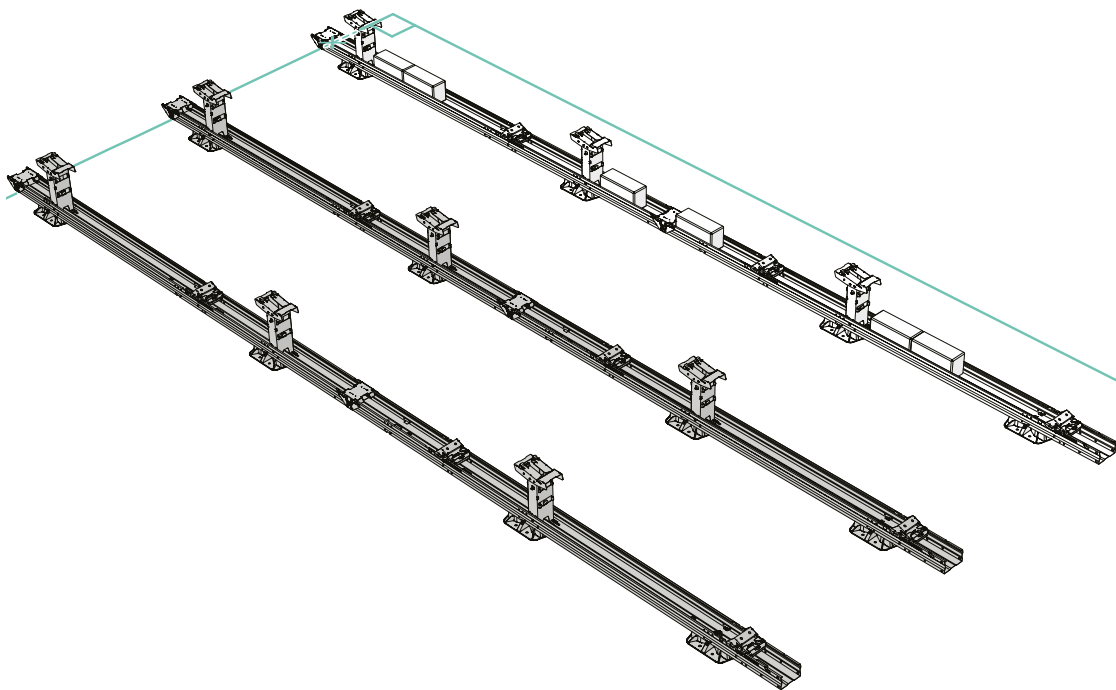

Repeat step 2.3. Tilt up the high base until it clicks into upright position.

6 Use measuring bars to determine the distance between the units

! Ensure correct orientation of the measuring bars.

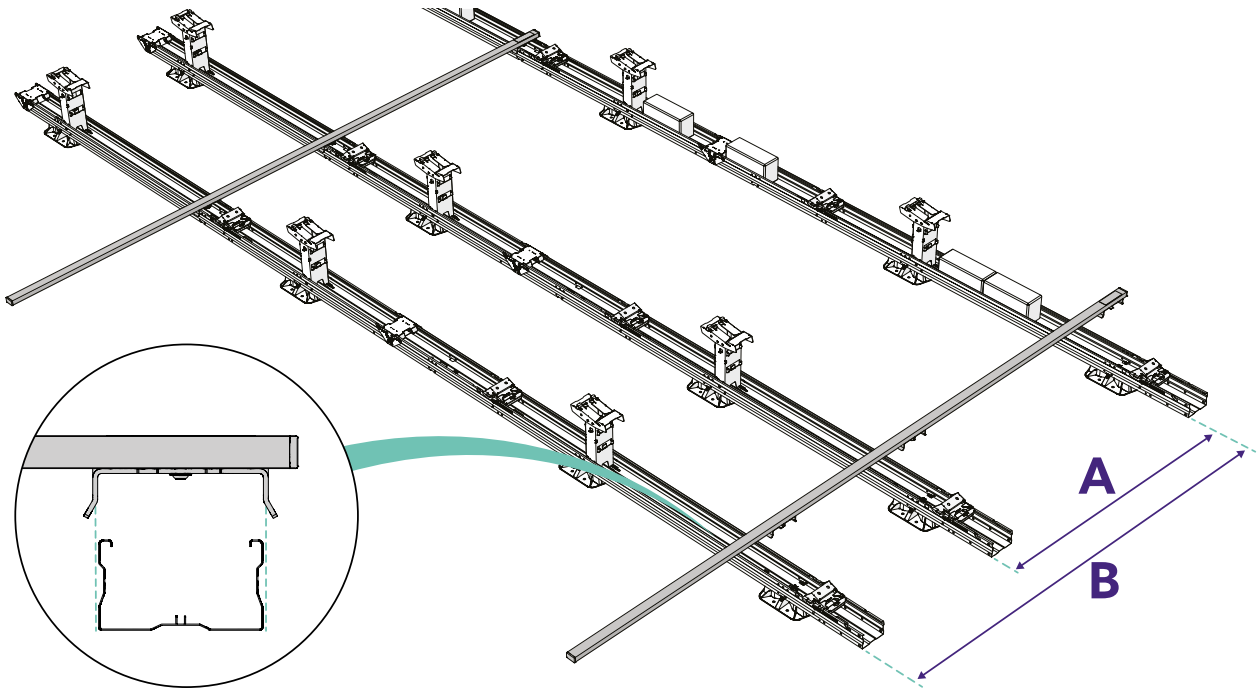

- Repeat step 2.4. Place (temporary) ballast to prevent the unit from accidentally moving.
- Repeat step 2.5. Place the next two units on the roof.
- Repeat step 2.6. Use measuring bars to determine the distance between the units
- Repeat step 2.3. Tilt up the high base until it clicks into upright position.

7 Use measuring bars to determine the distance between the units

! Ensure correct orientation of the measuring bars.

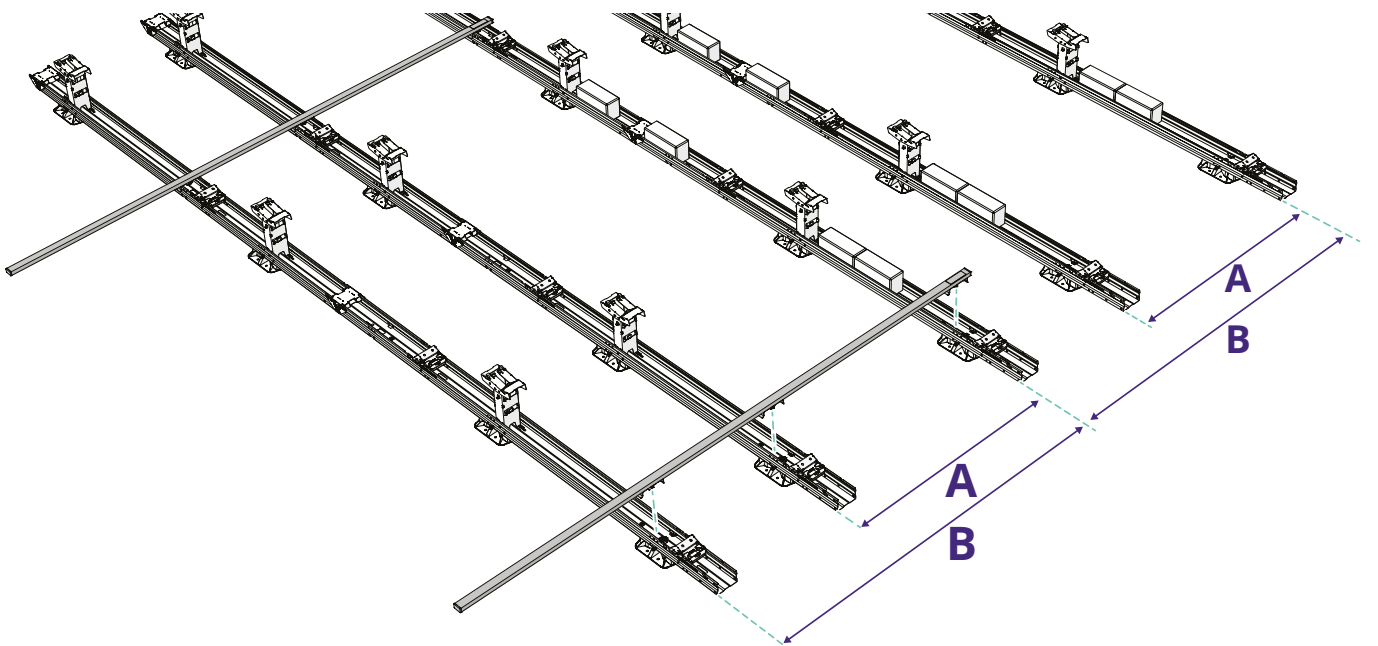

- Repeat step 2.4. Place (temporary) ballast to prevent the unit from accidentally moving.

3. Connect units with stabilizers

1 Fit stabilizers to each high base of the first four units.

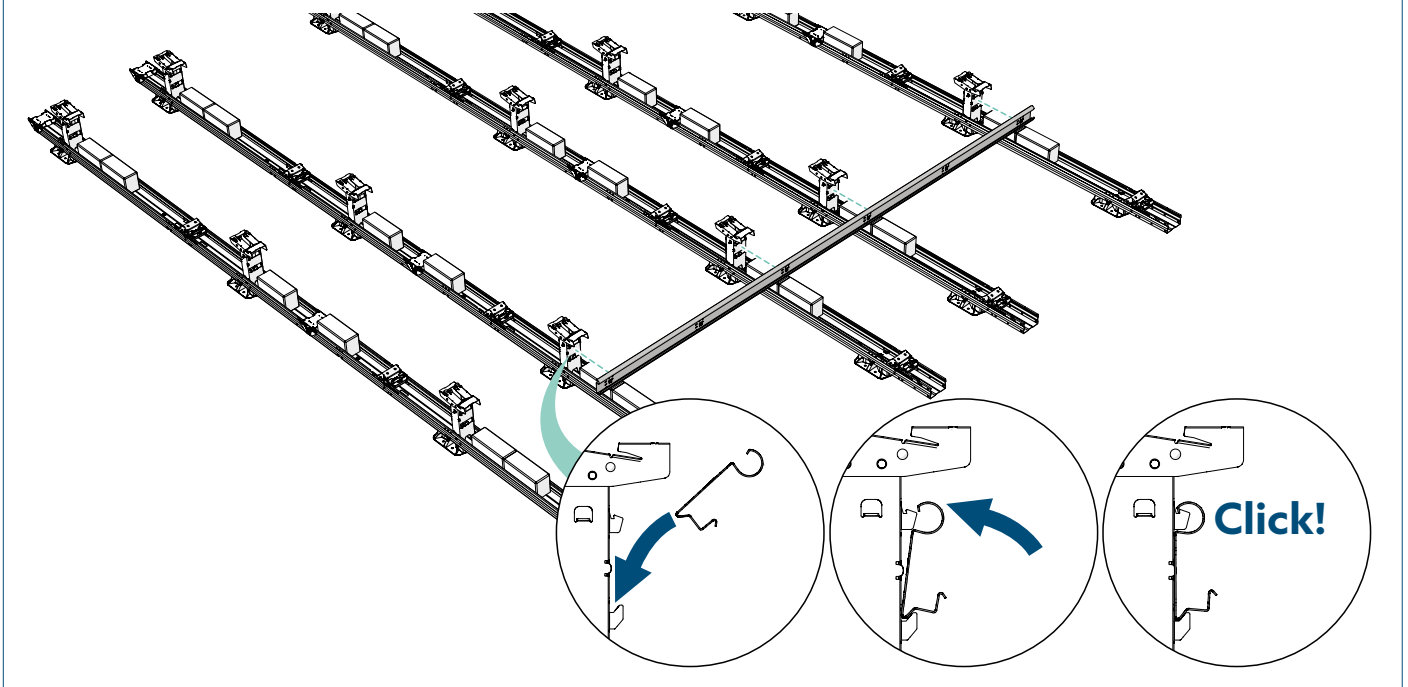

2 Attach the other stabilizers so that each stabilizer overlaps preceding stabilizer over two high bases

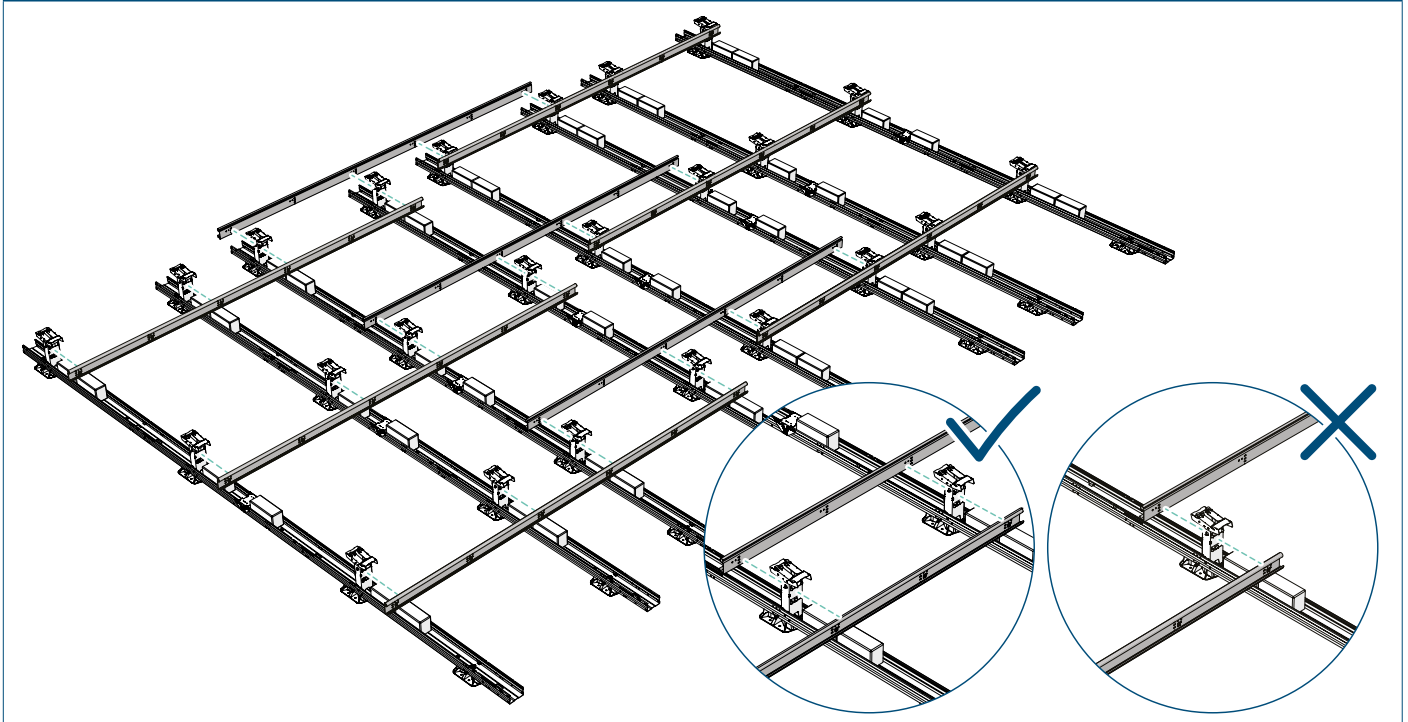

3 Install cable brackets to the rear of the rear stabilizer to bridge the gap between two stabilizers

i See Annex B: Cable management for more information on cable management.

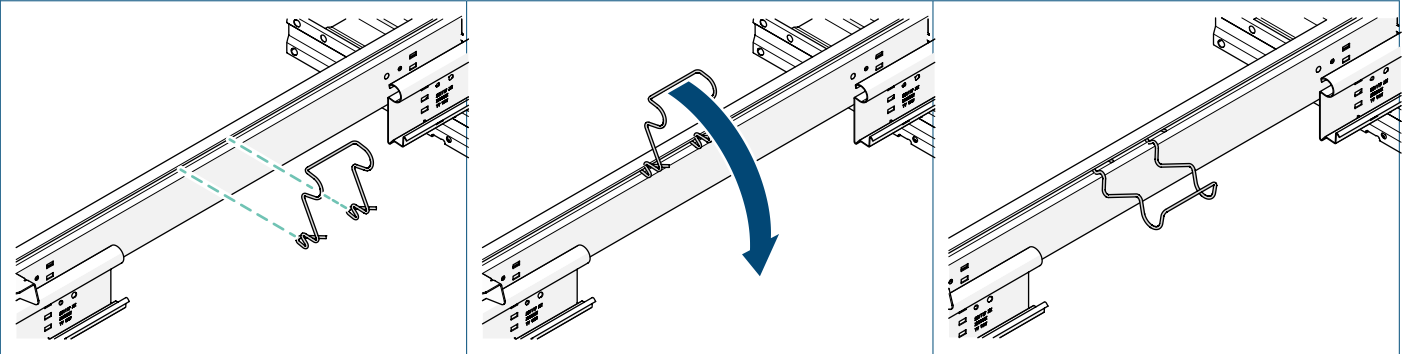

4 Extend the segment by attaching another unit using the pre-installed coupler

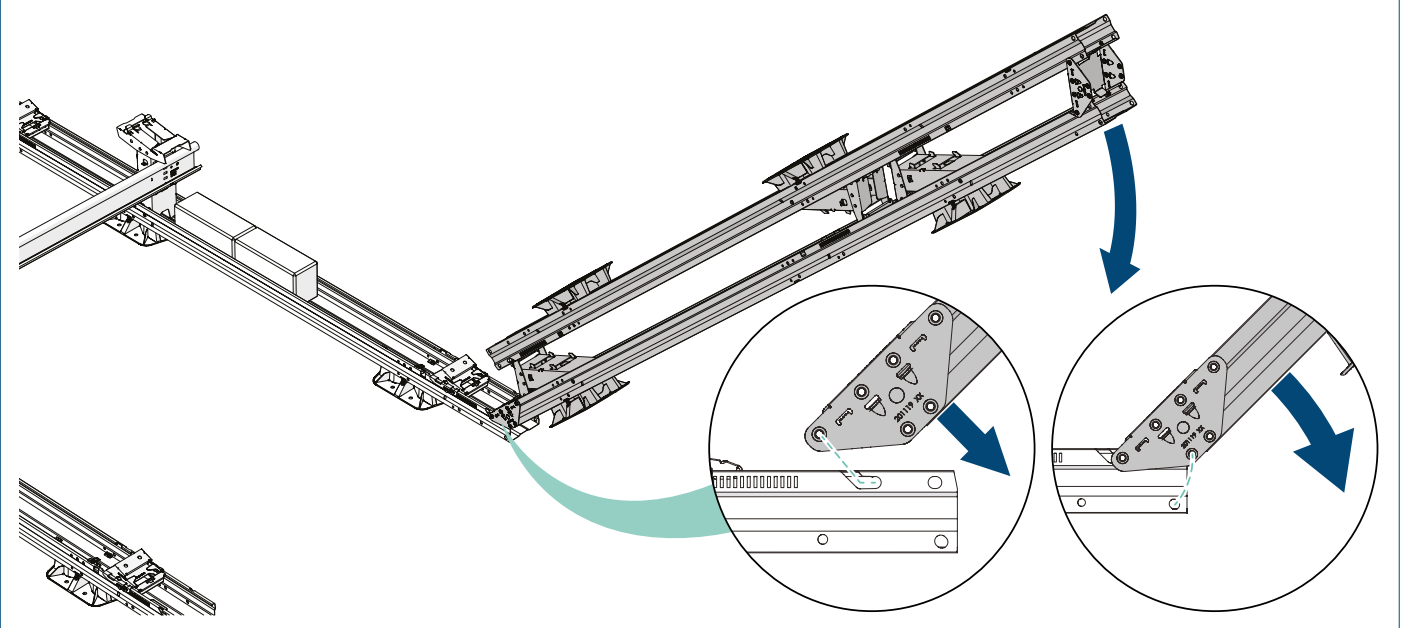

5 Optional: Place an extra base plate under the unit where necessary

i Check the project plan to see if additional base plates have been added under the units to reduce the concentrated load on the roof.

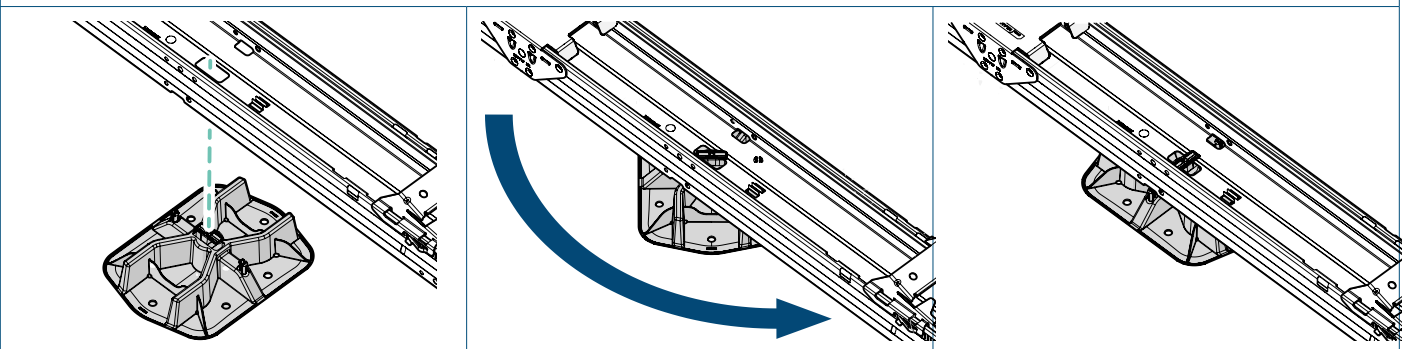

4. Place permanent ballast

The calculator determines the ballast needed for your project. Follow the instructions from the project plan determined by the calculator.

In this chapter we provide a general description of the five possible positions for the ballast.

! If anything changes in the layout of the solar panel field, the ballasting has to be recalculated.

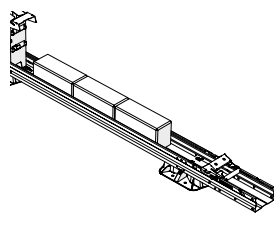
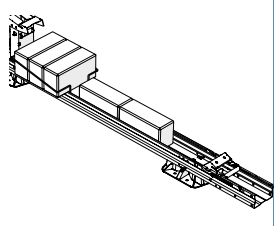
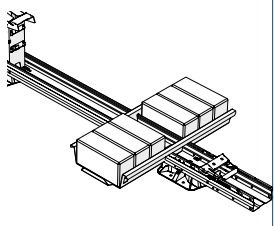
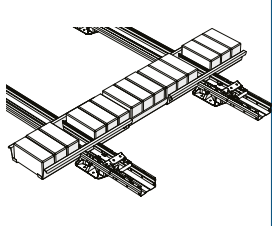
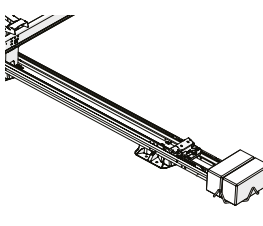
Position A	Position B	Position C	Position D	Position E
				
See project plan: "U; XX kg" (Unit)	See project plan: "B; XX kg" (Bracket)	See project plan: "T; XX kg" (Tray)	See project plan: "E; XX kg" (Extender)	See project plan: "P; XX kg" (Perimeter)

Position A In the units

1 Place the ballast in the unit.

! Place a maximum of three bricks in the unit. A fourth brick will not fit under the solar panel.

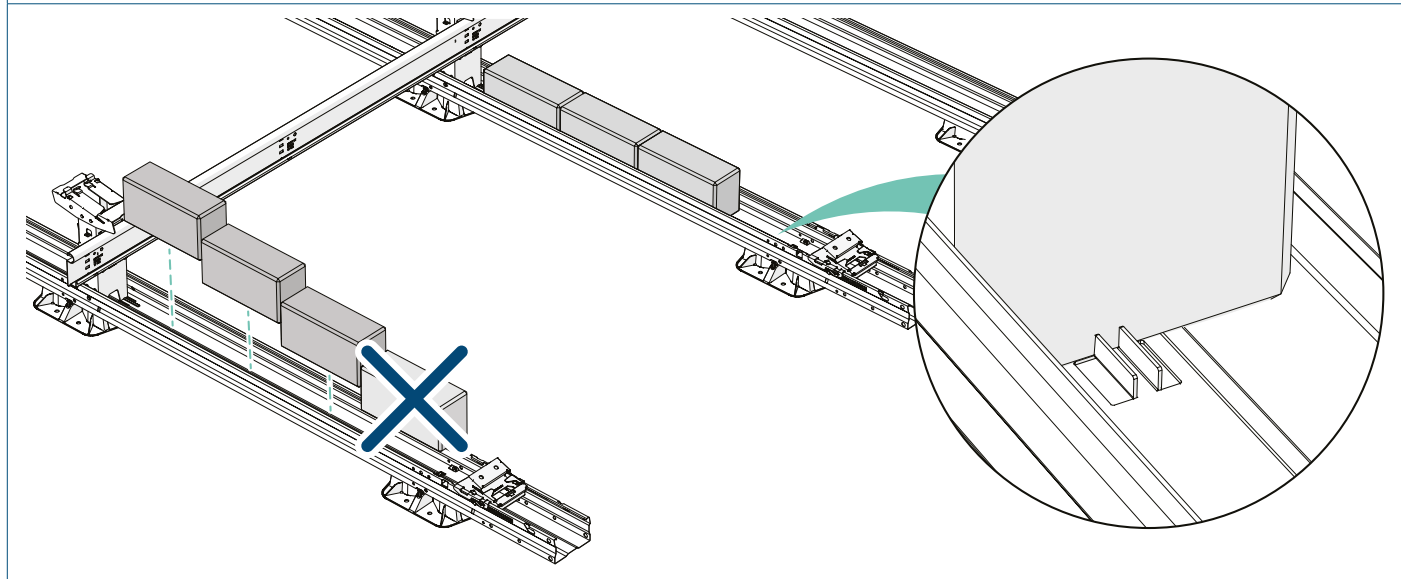

Position B In ballast brackets

- 1 Squeeze the hooks of the ballast bracket together and place the bracket next to the high base in the unit.

! Do not position the ballast bracket on the locking tab of the high base. This can unlock the high base compromising the structural strength.

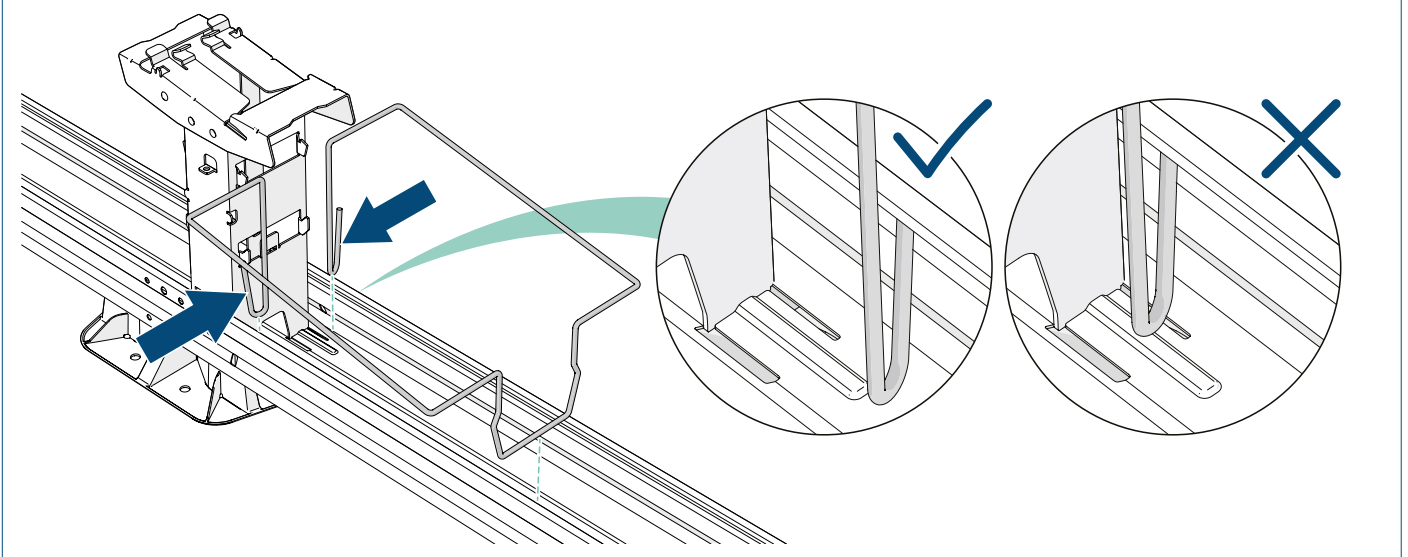

- 2 Fill the ballast bracket and, if necessary, the unit with bricks.

! Place a maximum of two bricks in the unit in combination with the ballast bracket. A third brick will not fit under the solar panel.

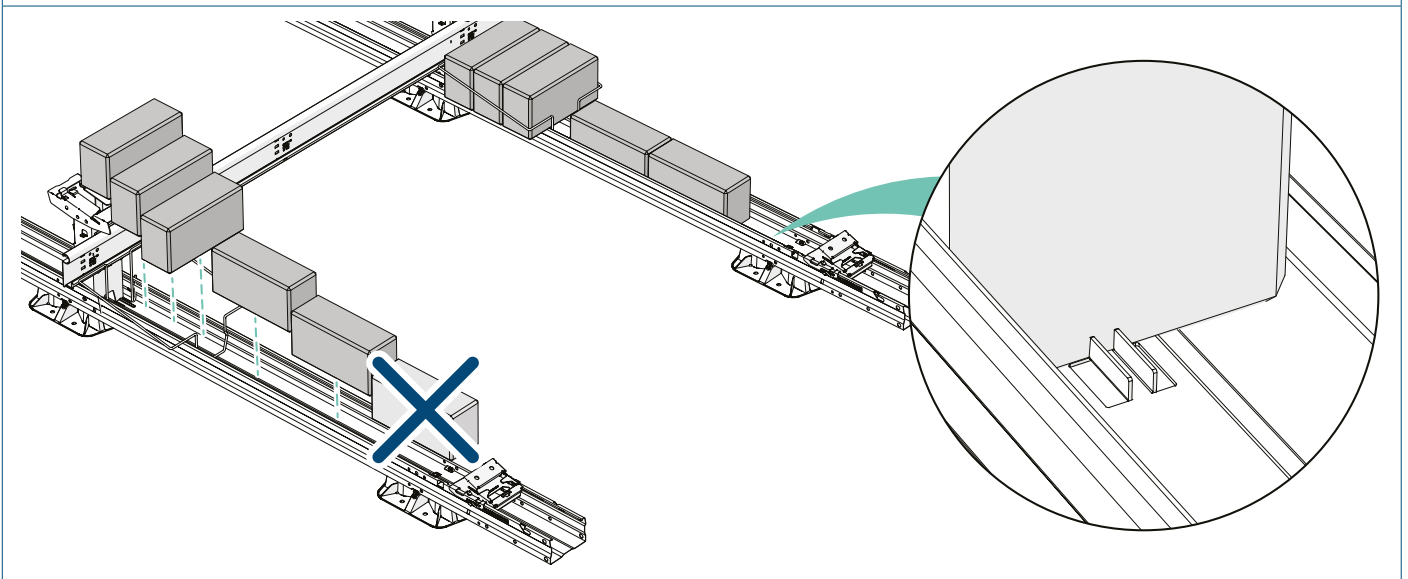

Position C In ballast trays

- 1 Push the ballast tray over the unit in the position specified in the project plan.

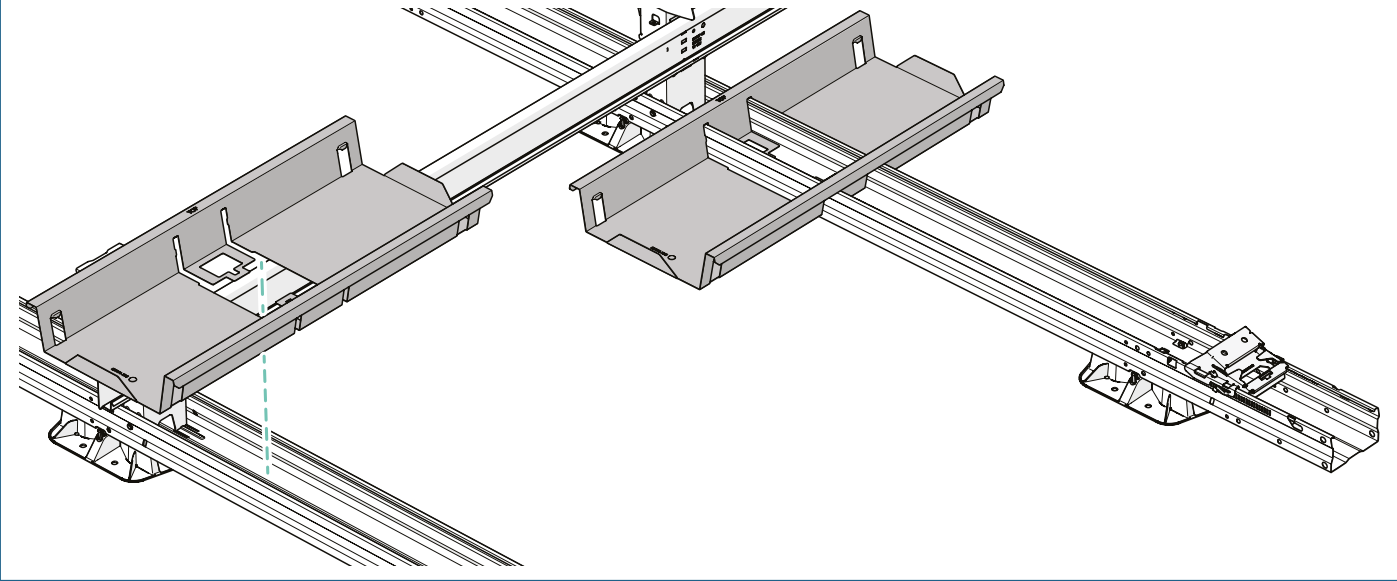

- 2 Fill the ballast tray with bricks.

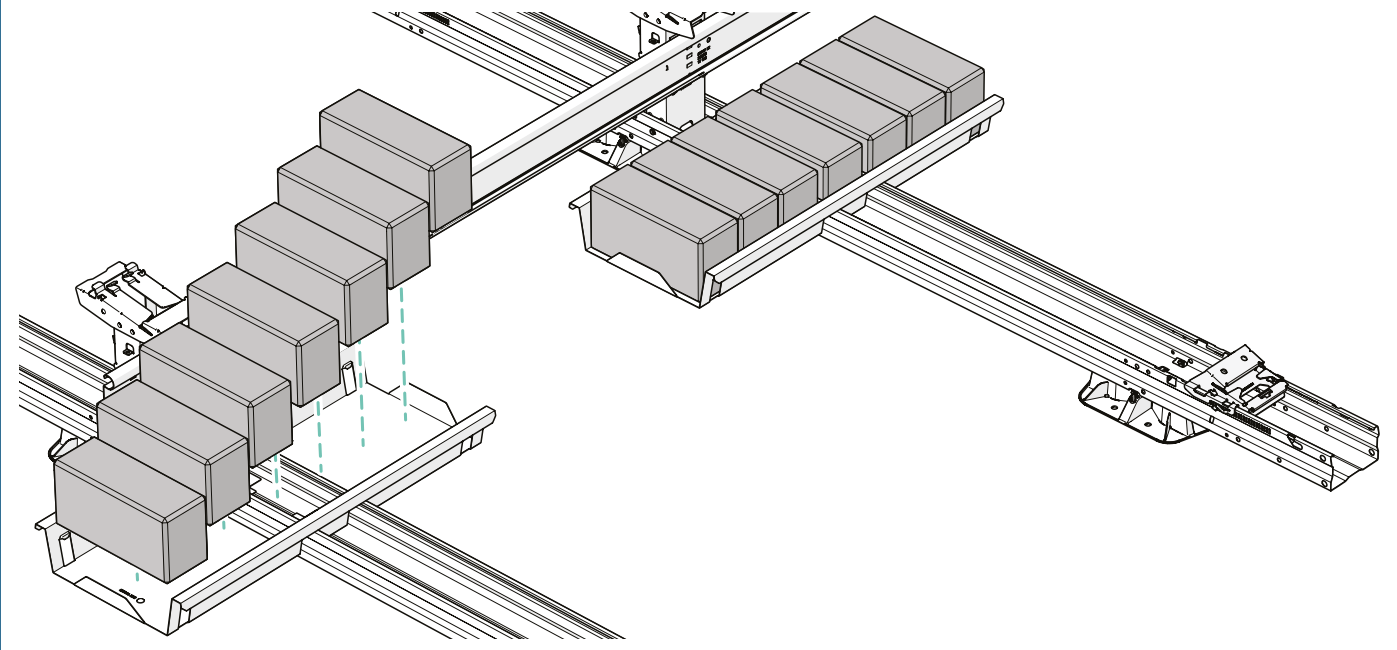

3 If the project plan specifies more than one ballast tray, slide the outer ballast tray against the tabs in the unit. In this array you can place a maximum of three ballast trays in a row.

! Place the bricks in the outer ballast tray on the flat side, otherwise they will not fit under the solar panel.

i Follow the project plan for the required positions and quantities of ballast.

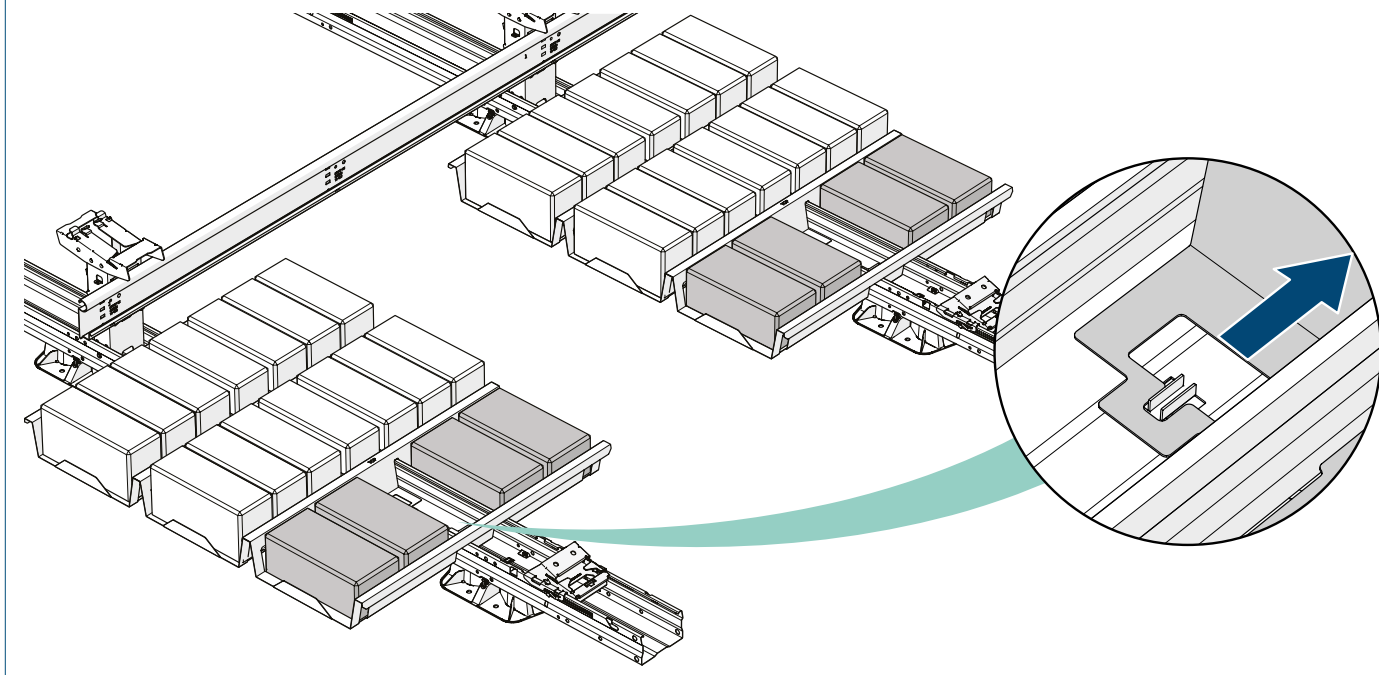

Position D In ballast trays with ballast tray extenders

- 1 Push the ballast tray over the unit in the position specified in the project plan.

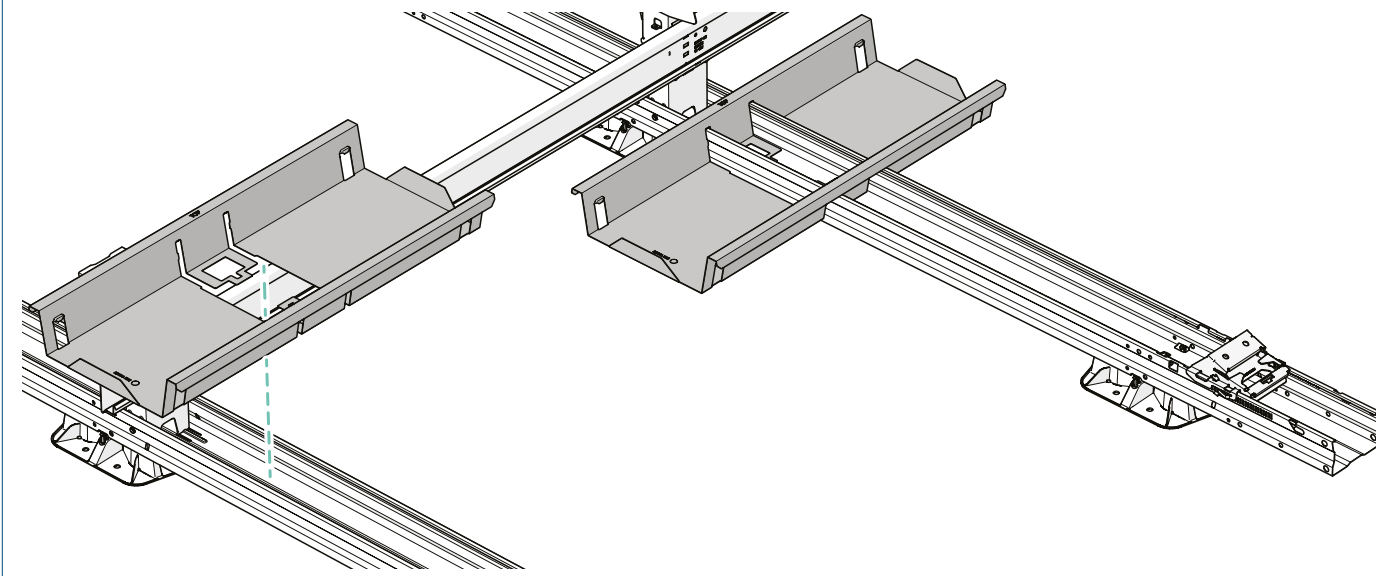

- 2 Connect two ballast trays together with the ballast tray extender.

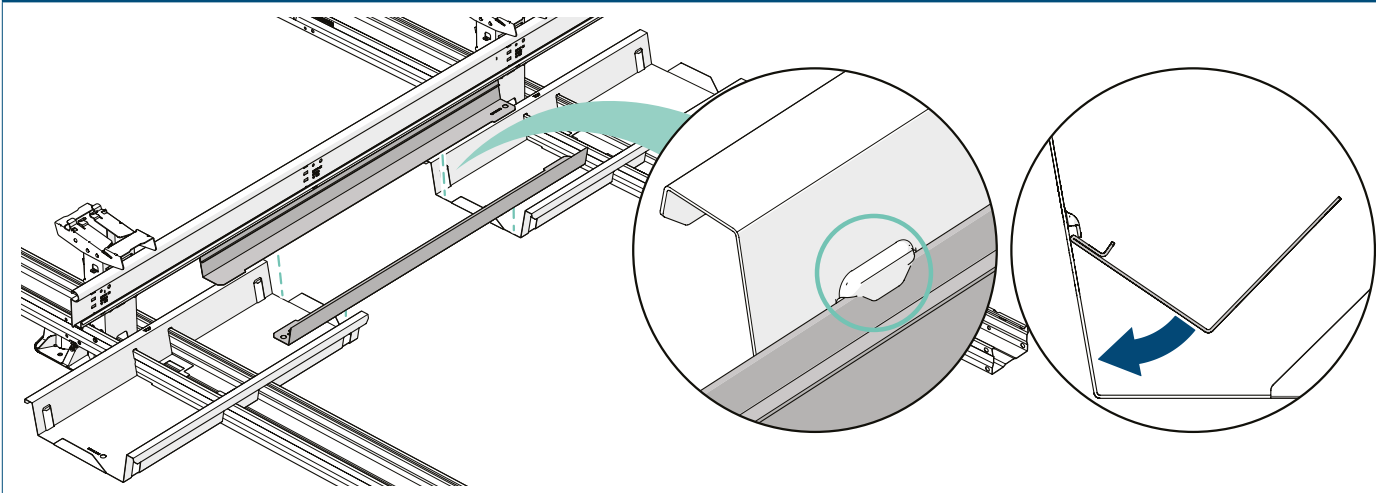

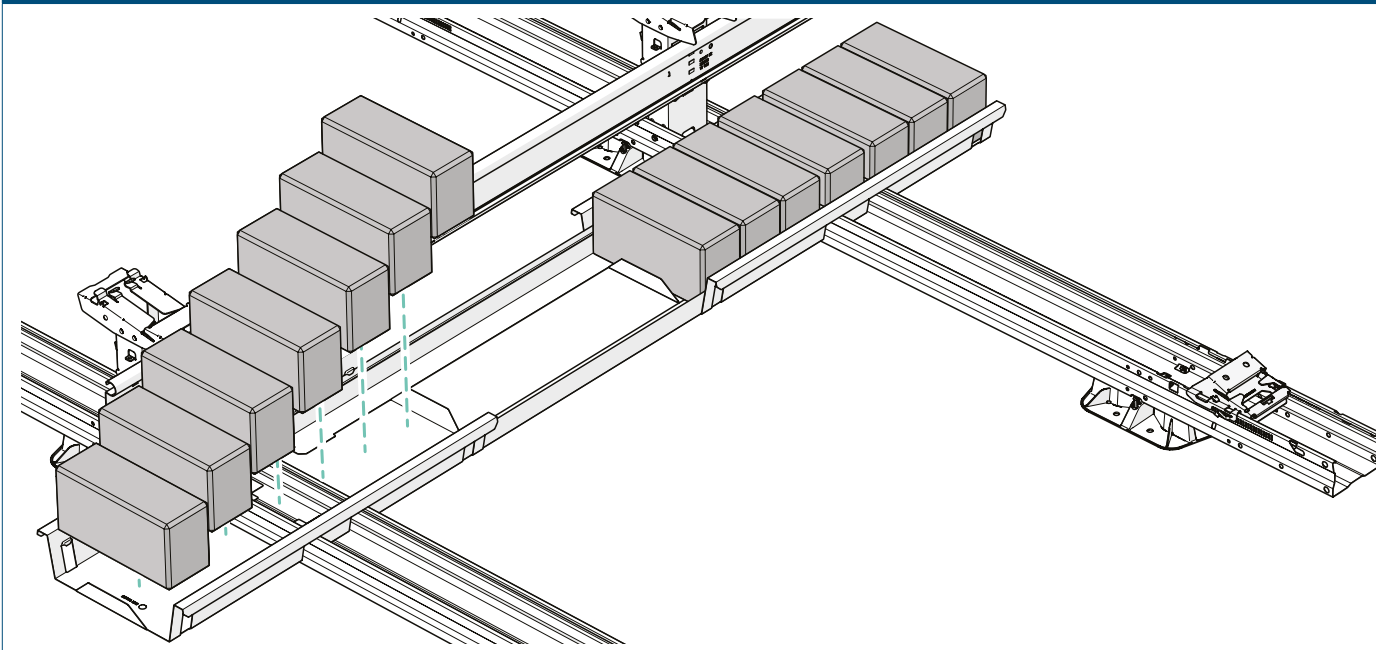

- 3 Fill the ballast trays with bricks.

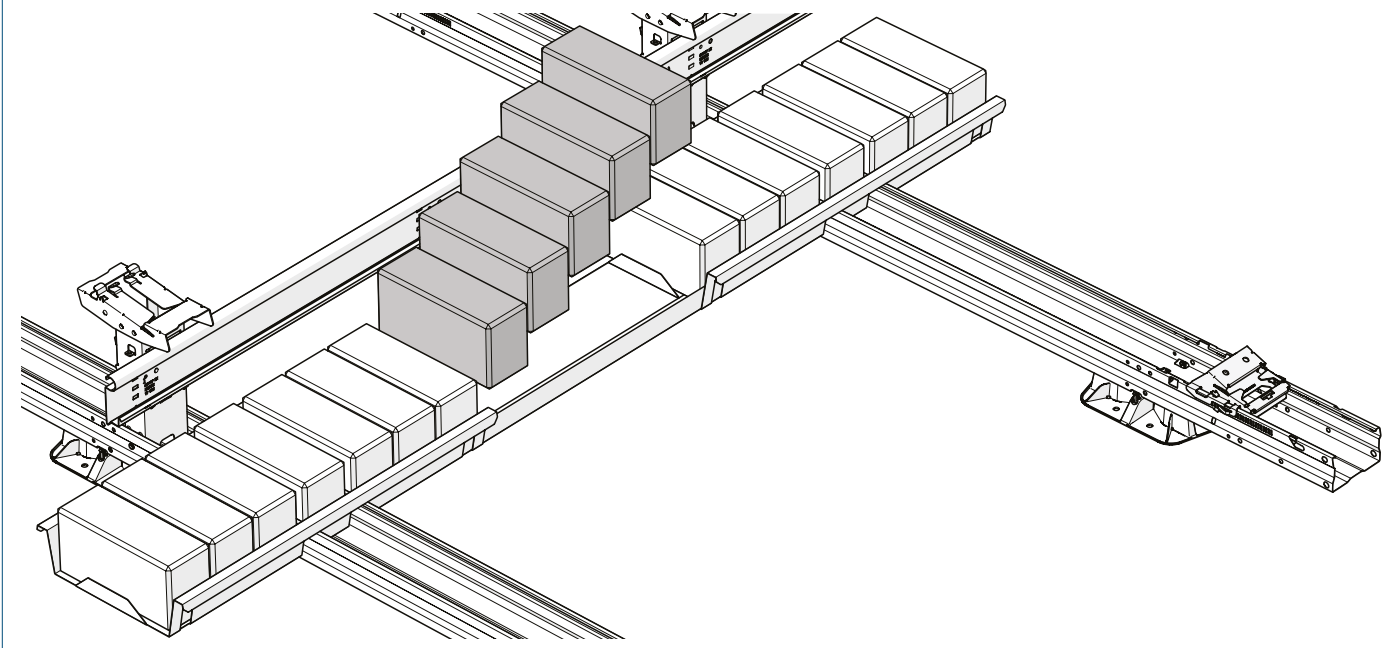

4 Fill the ballast tray extender with bricks.



5 If the project plan specifies more than one ballast tray, slide the outer ballast tray against the tabs in the unit. In this array you can place a maximum of three ballast trays in a row.

-  Place the bricks in the outer ballast tray on the flat side, otherwise they will not fit under the solar panel.
-  Follow the project plan for the required positions and quantities of ballast.

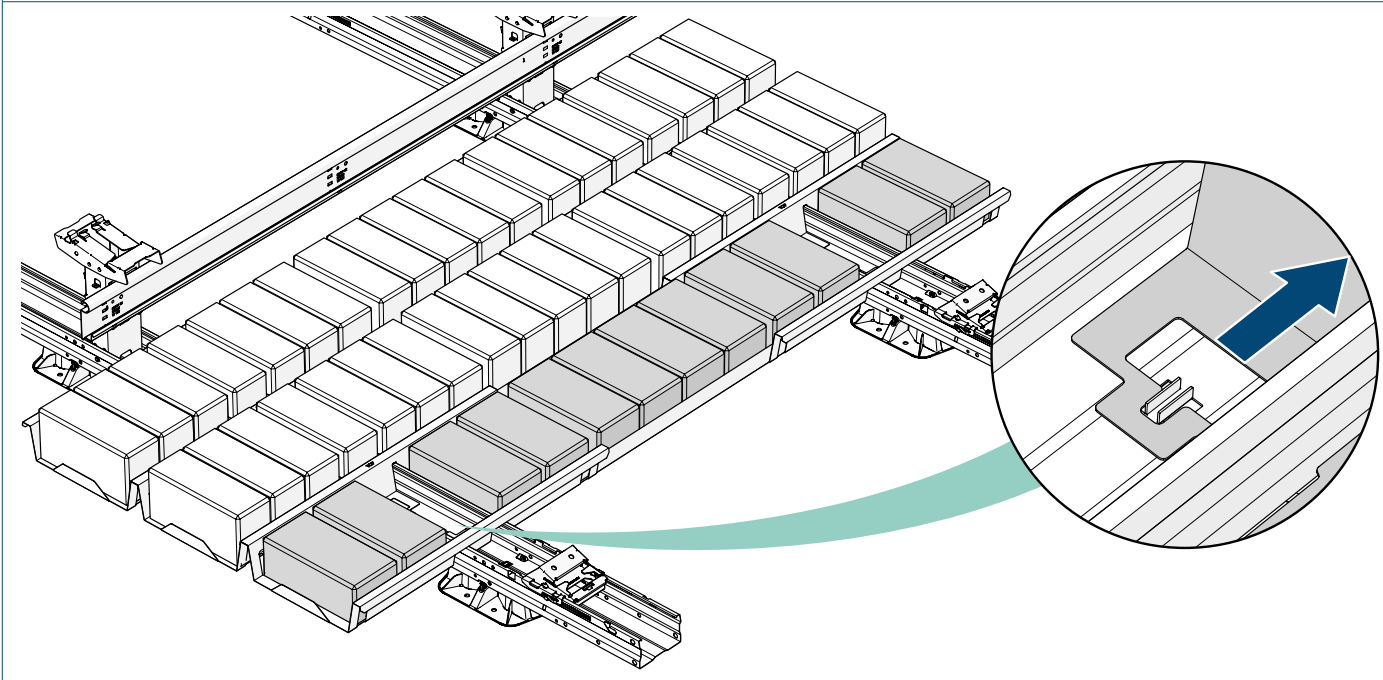

Position E In perimeter ballast brackets

- 1 Squeeze the hooks of the perimeter ballast bracket and insert the bracket into the end of the unit.

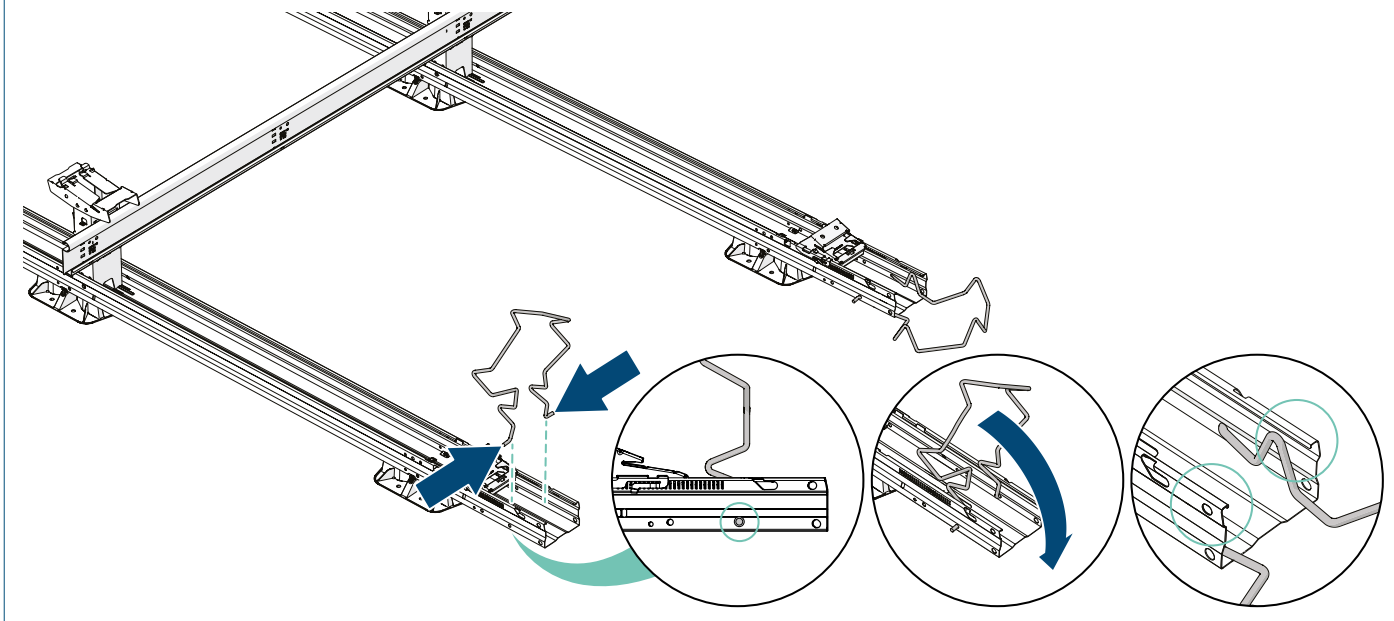

- 2 Always fill the perimeter ballast bracket with two bricks.

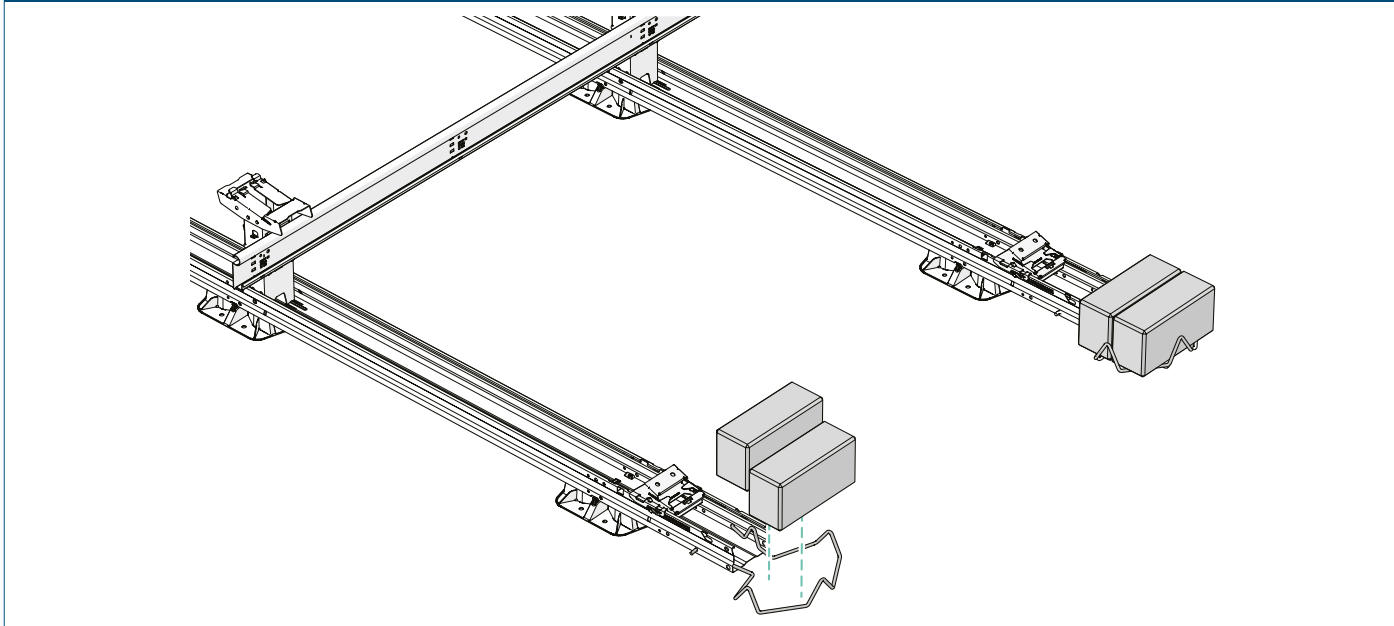

5. Mounting the first solar panel

! Do not mount any solar panels if there may be strong winds in the time between mounting the solar panel and wind deflectors. Immediately mount the wind deflectors after mounting a field of solar panels.

1 Place the solar panel upright on two high bases and align the solar panel in the middle.

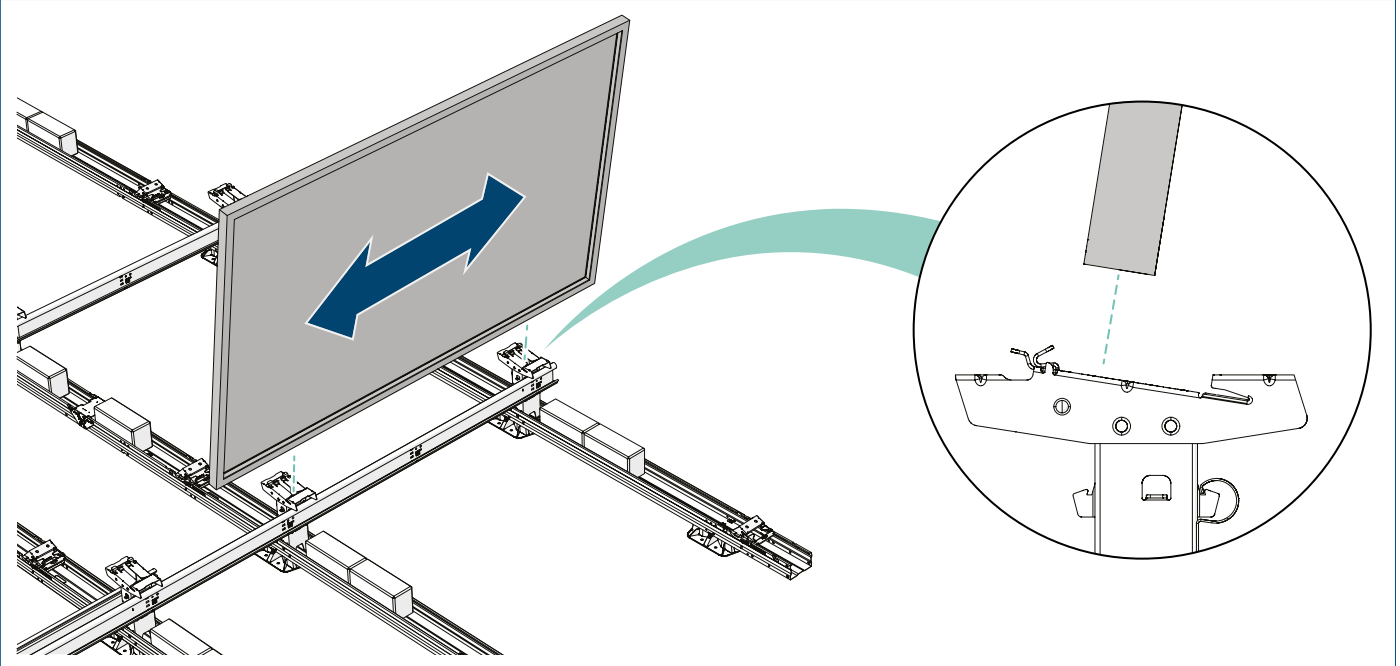

2 Carefully tilt the solar panel on the panel clamps.

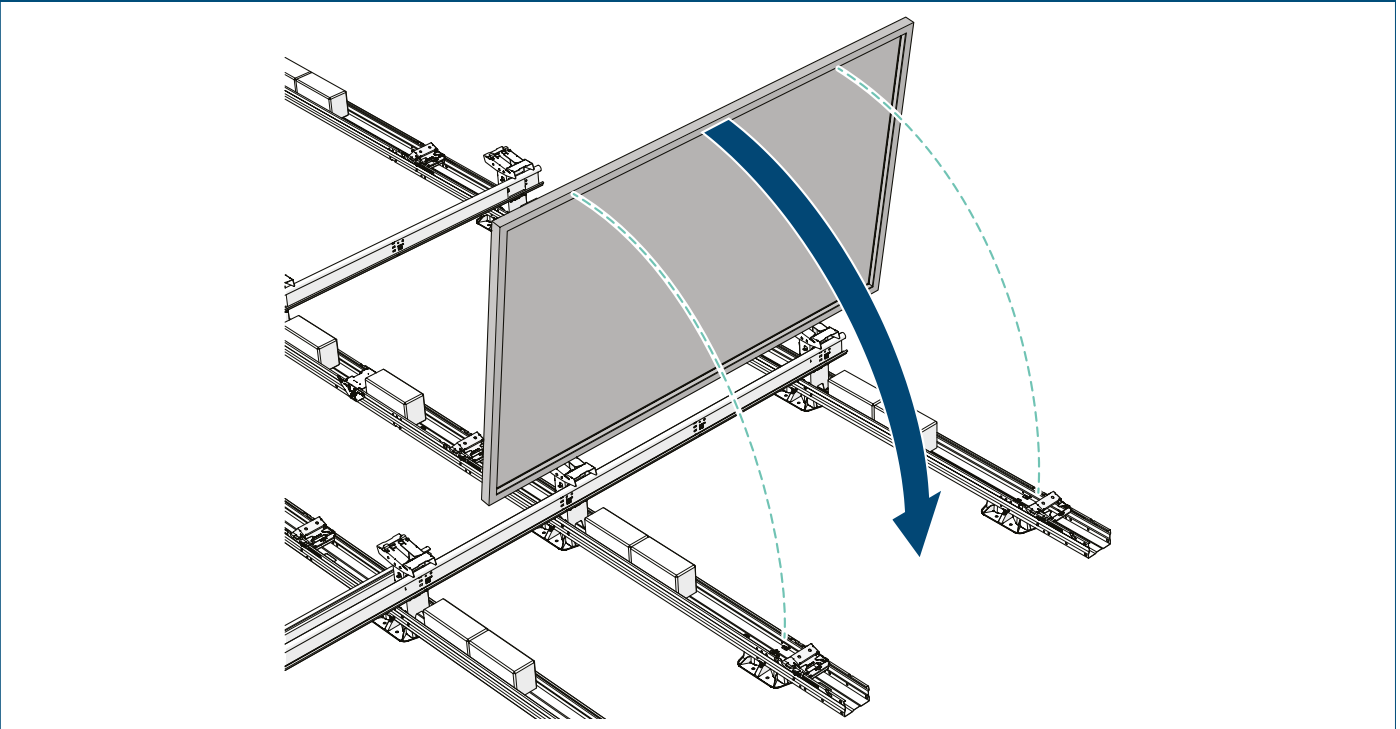

3 Pull the solar panel towards you so that the solar panel frame hooks into the high bases.

i The solar panel should now rest on the lower section of the panel clamp. If the solar panel frame rests on the top part of the panel clamp, push the panel clamp backwards using the unlock tool. See Appendix for more information.

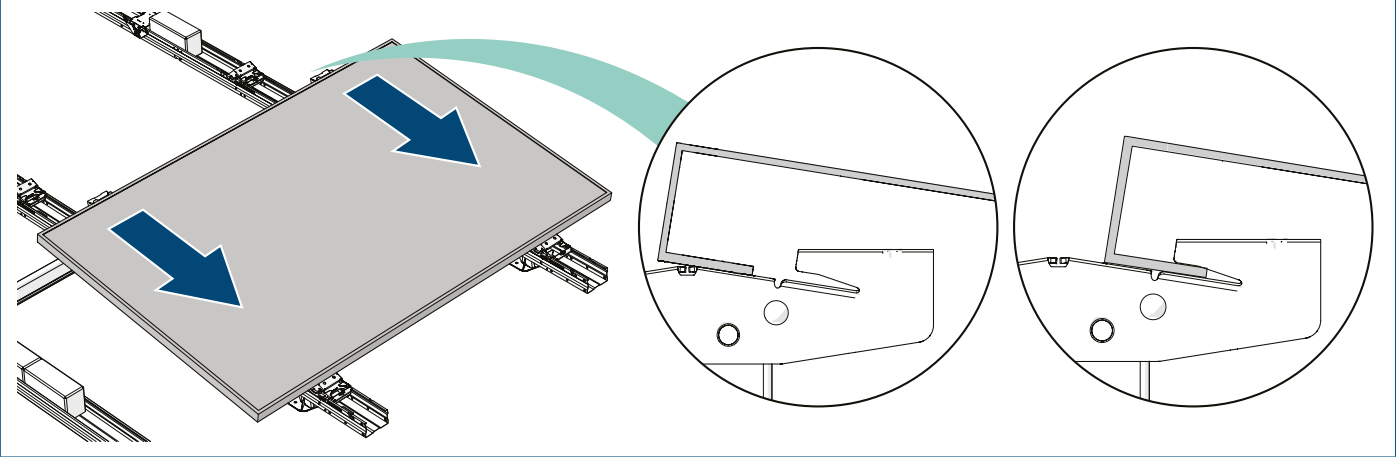

4 Pull the panel clamp towards you until they can go no further, so the panel clamps hook into the frame of the solar panel.

5 Pull the locking mechanism up through the clamp handle until it clicks into place to lock the solar panel in place.

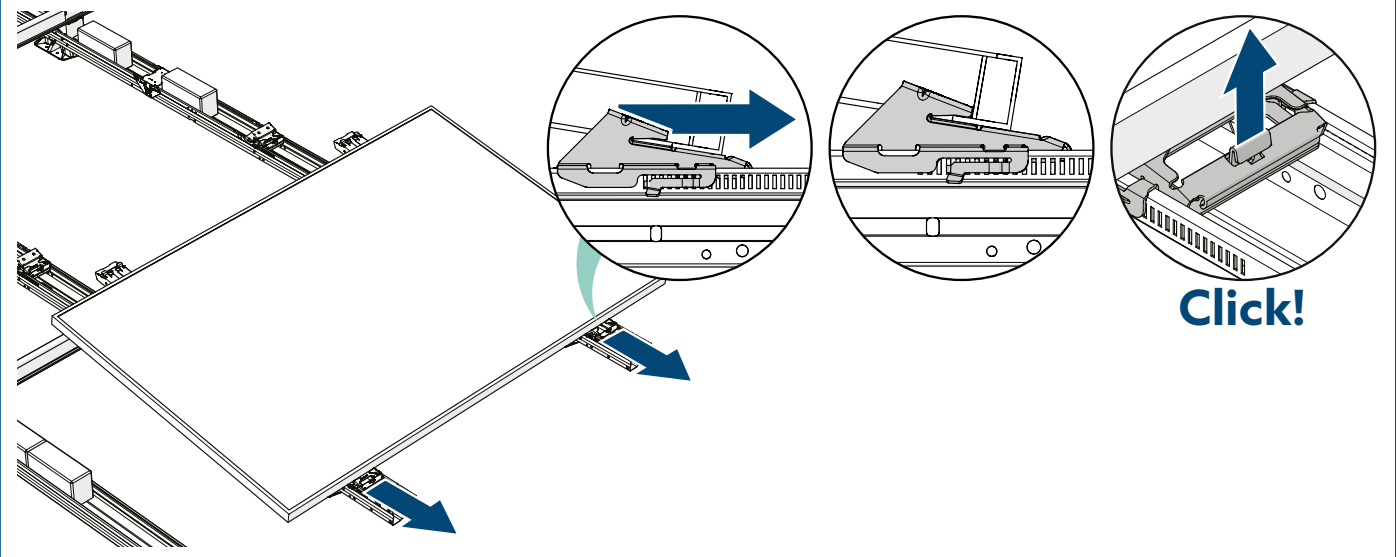

6. Mounting the following solar panels

- 1 Place the spacer tool on the installed solar panel.

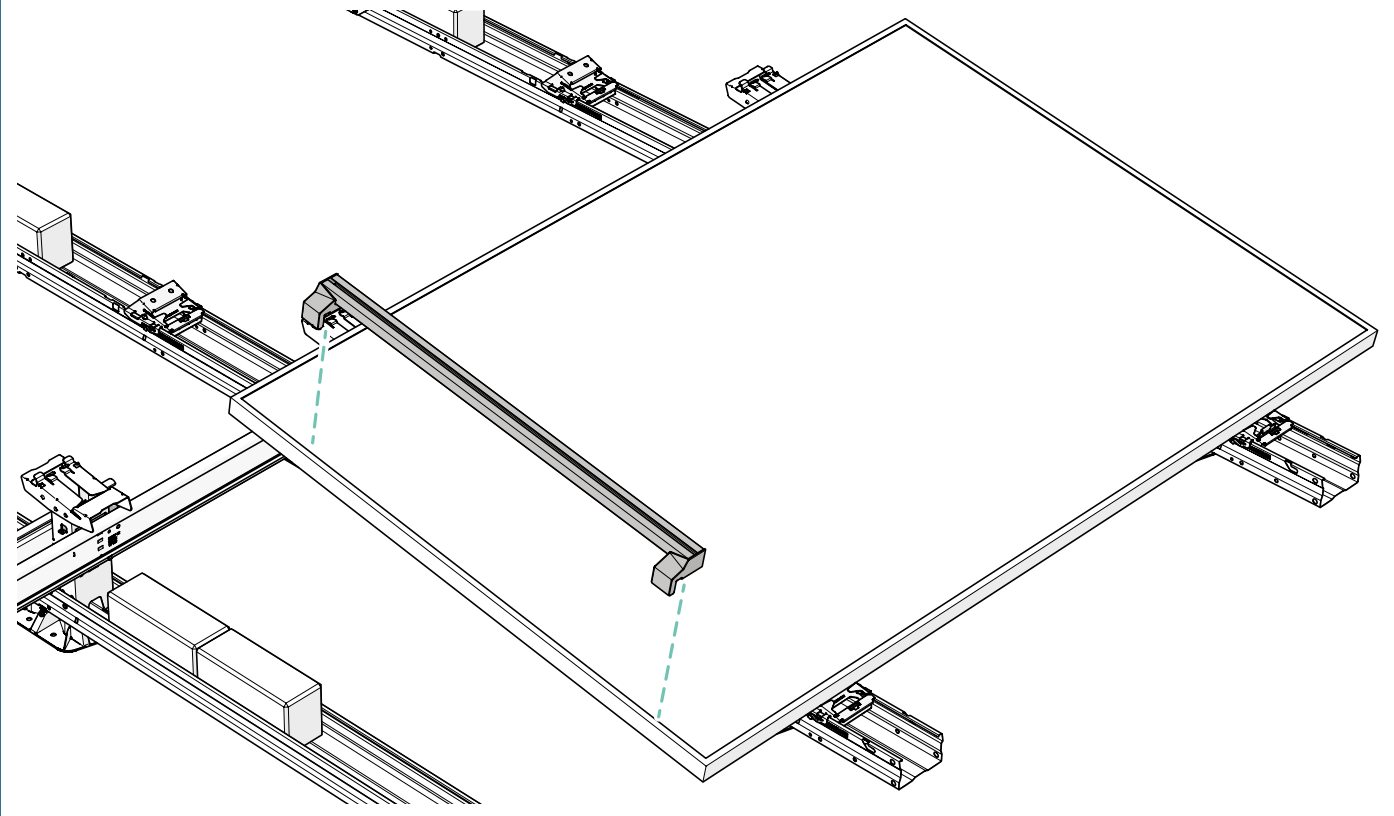

- 2 Place the solar panel upright on two high bases and align the solar panel in the middle.

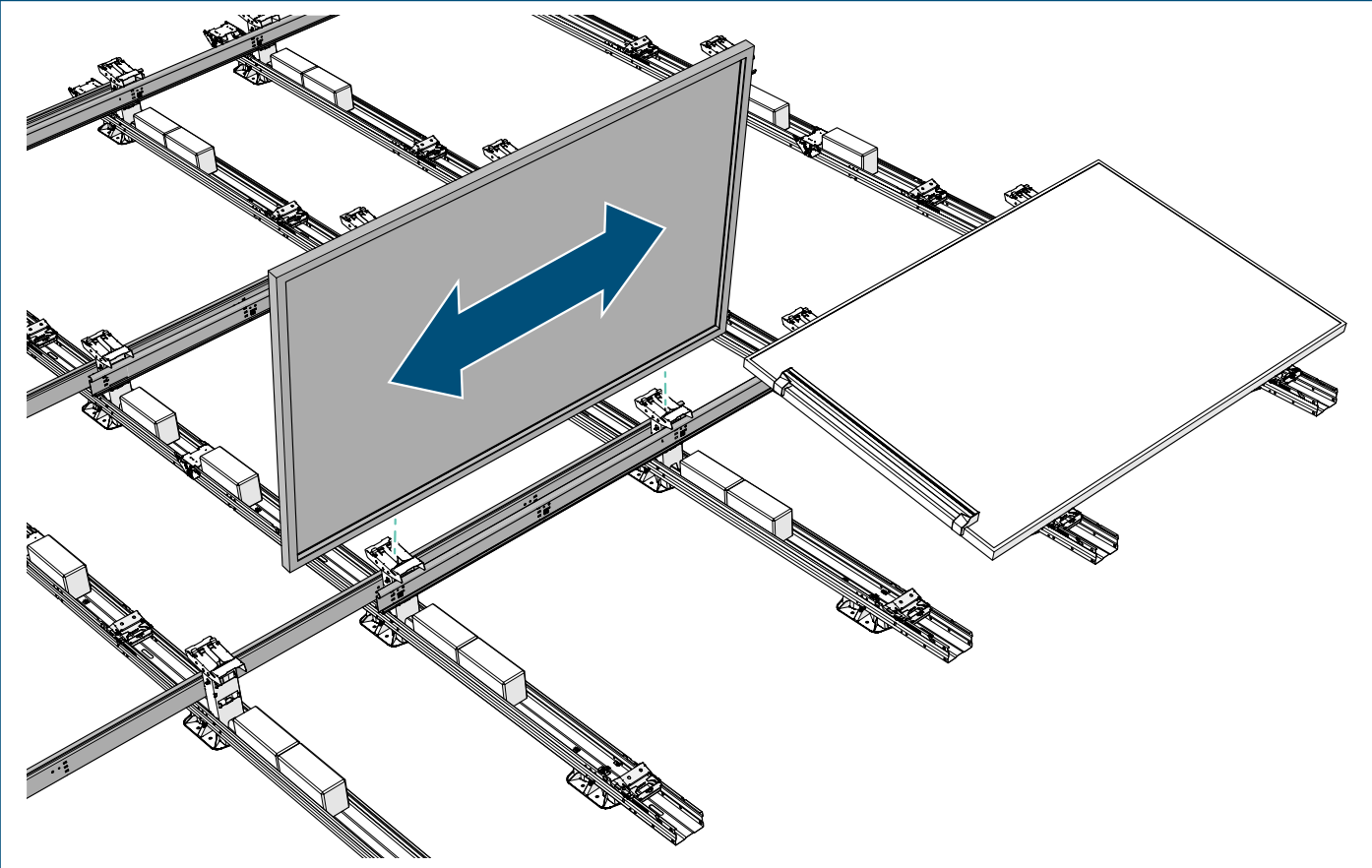



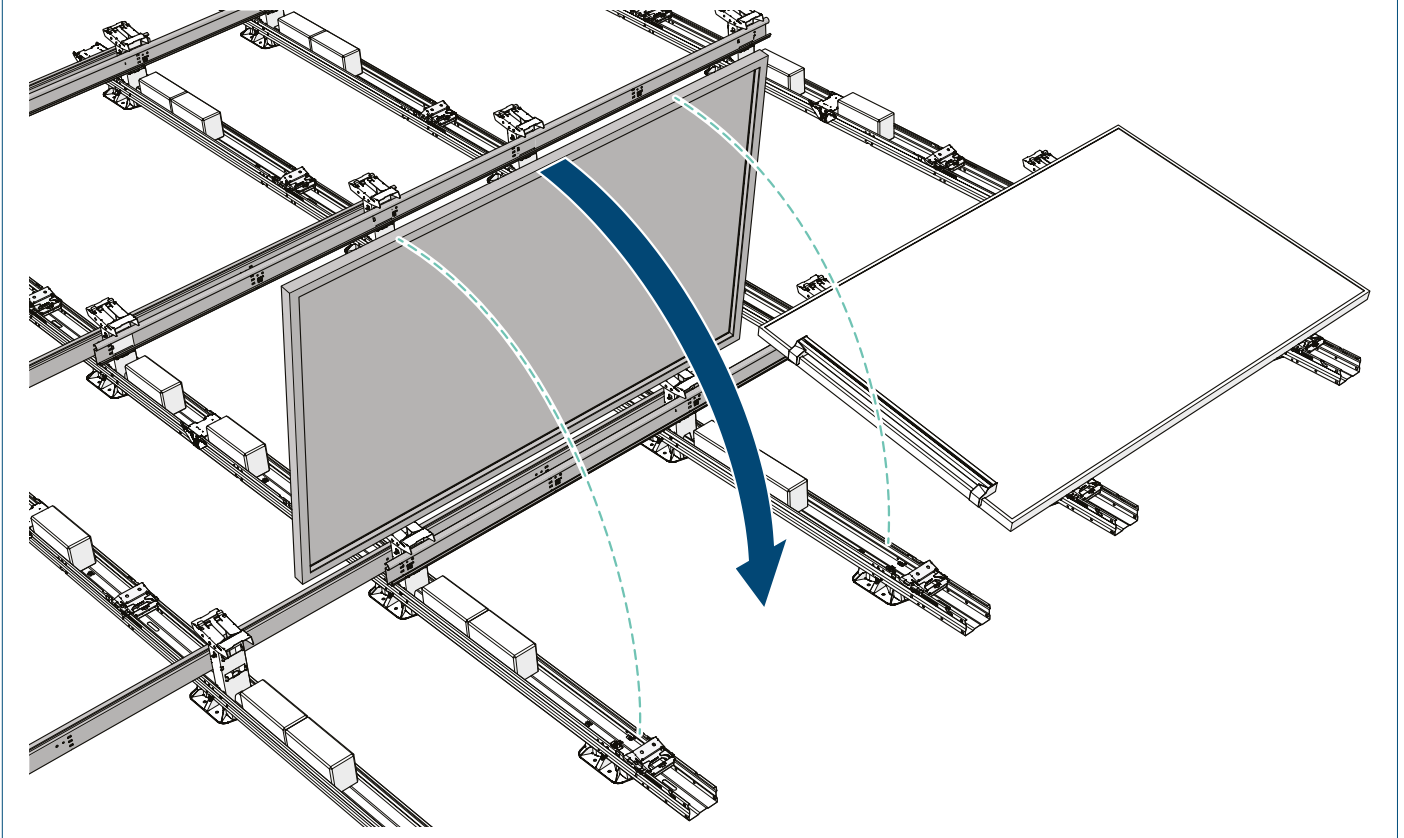

3 Carefully tilt the solar panel on the panel clamps.

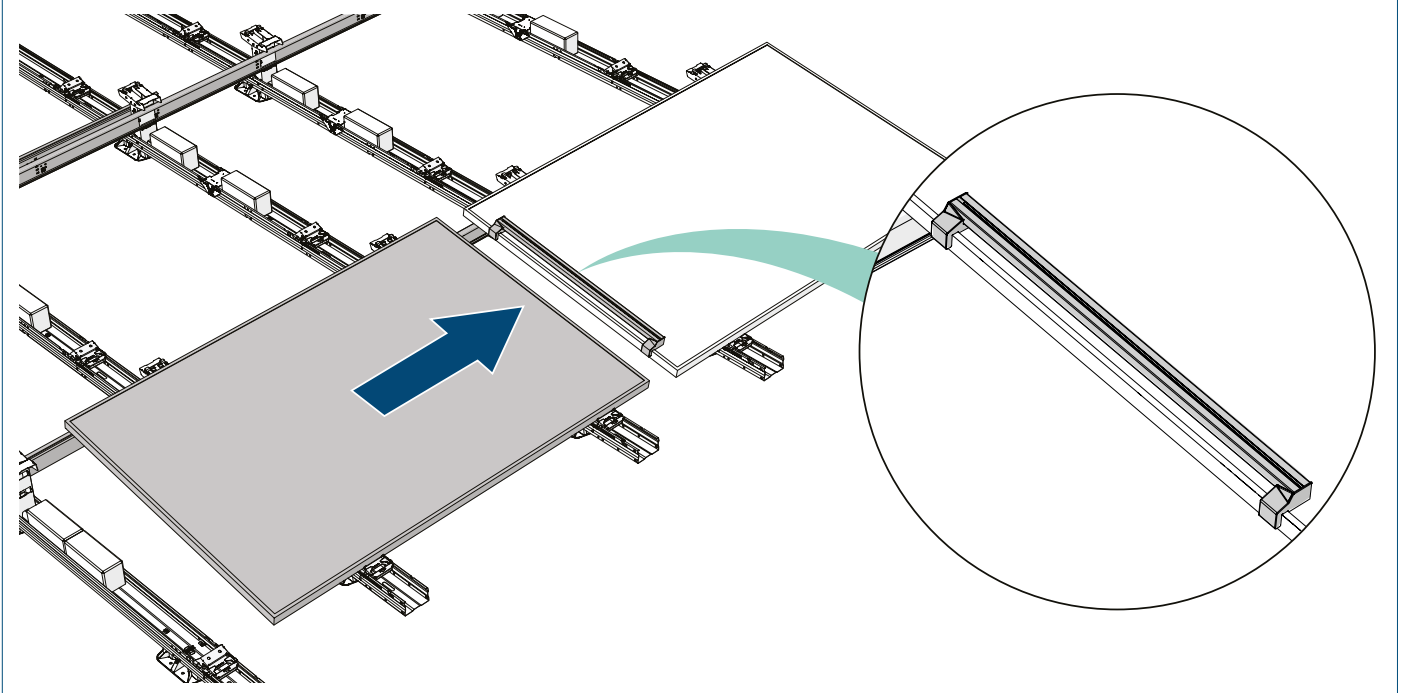

4 Slide the panel against the spacer tool



- | | |
|---|---|
|  | Repeat step 6.3. Pull the solar panel towards you so that the solar panel frame hooks into the high bases. |
|  | Repeat step 6.4. Pull the panel clamp towards you until they can go no further, so the panel clamps hook into the frame of the solar panel. |
|  | Repeat step 6.5. Pull the locking mechanism up through the clamp handle until it clicks into place to lock the solar panel in place. |
|  | Repeat the steps in this chapter for all panels. |

7. Placing Rear Deflectors

- 1 Lay the rear deflector loosely on the designated slot in the high bases.

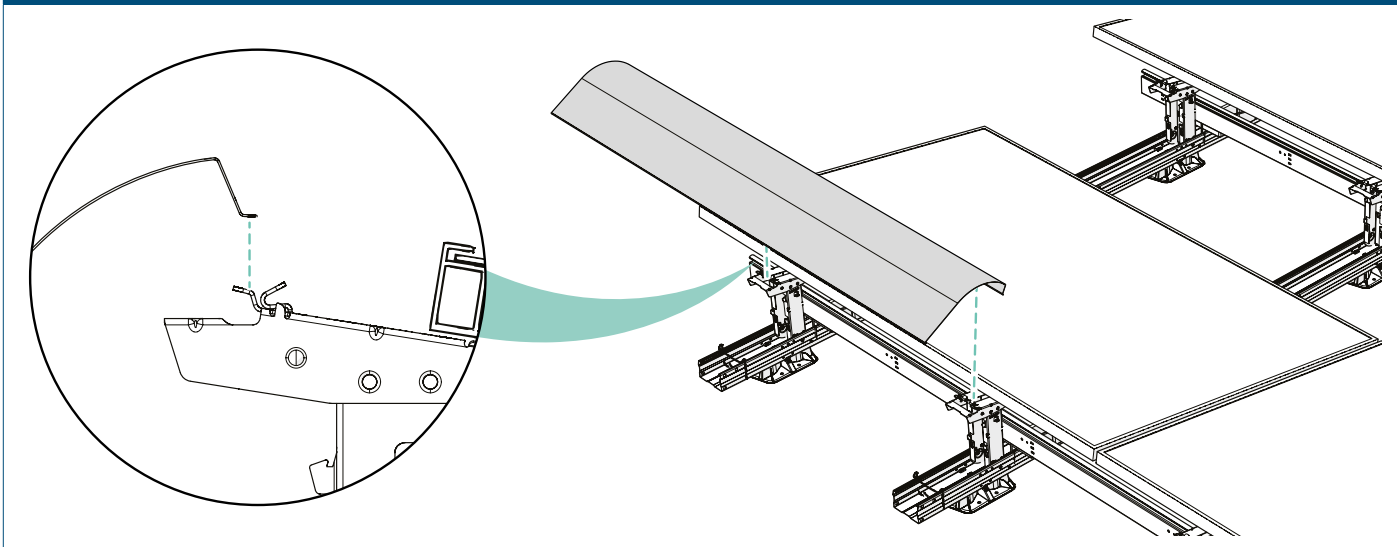

- 2 Align the rear deflector with the panel.

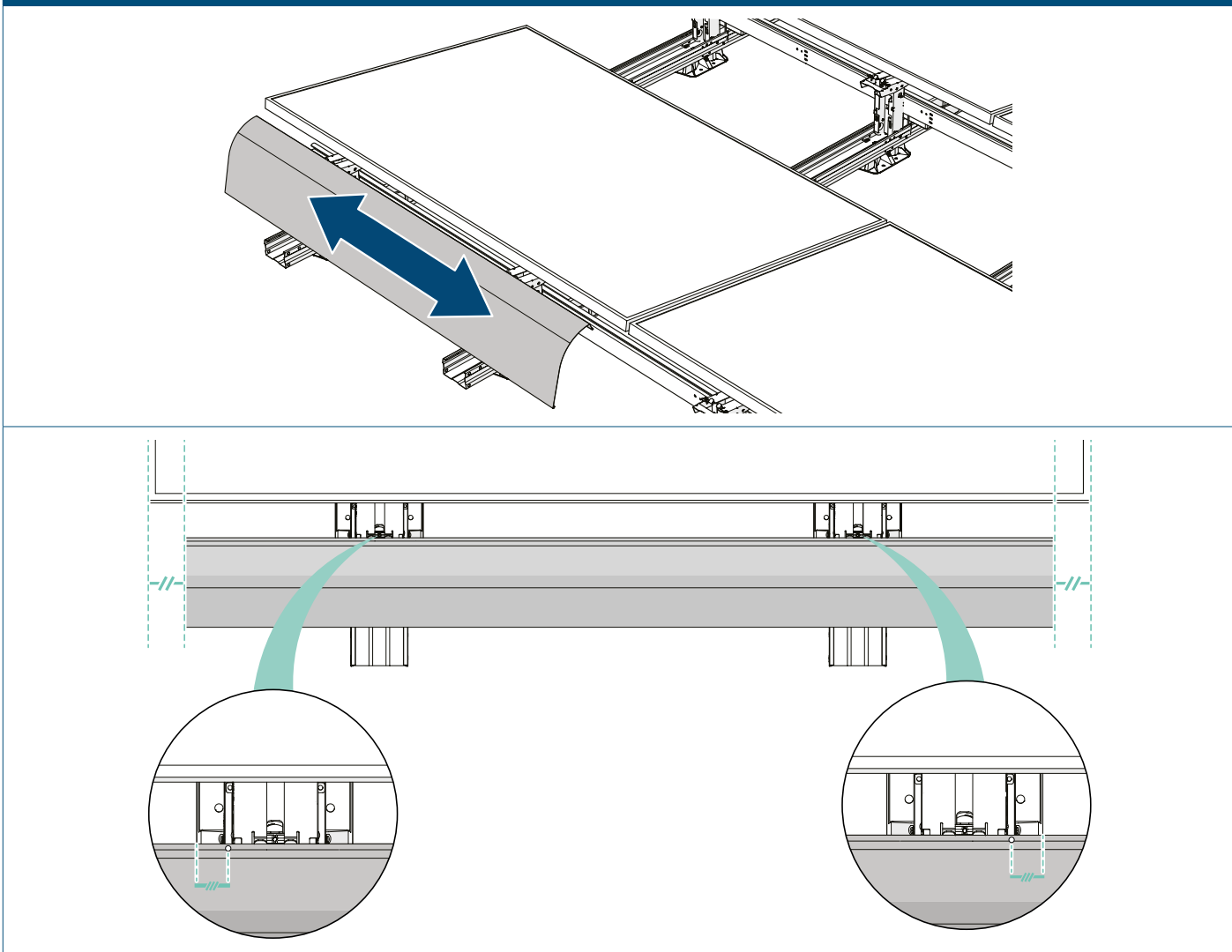

- i** Use the holes in the top of the rear deflector to centre it properly.

3 Tilt the rear deflector up and hook the top into the slot of the high base.

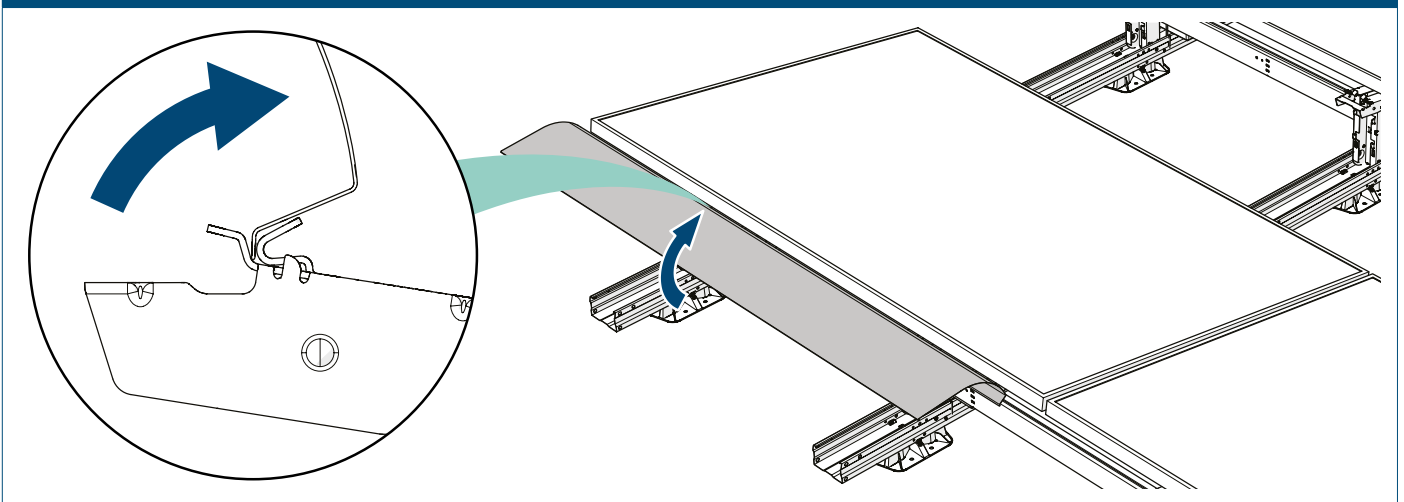

4 Lower the rear deflector until it rests on the units.

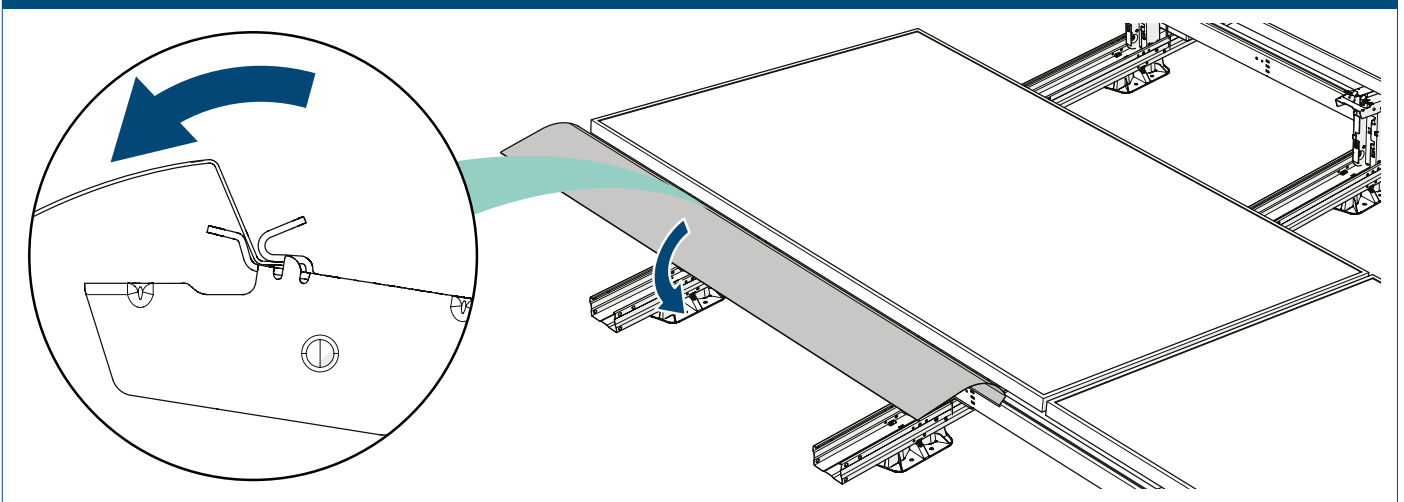

5 Hook a rear deflector clip into the flange on the underside of the rear deflector.

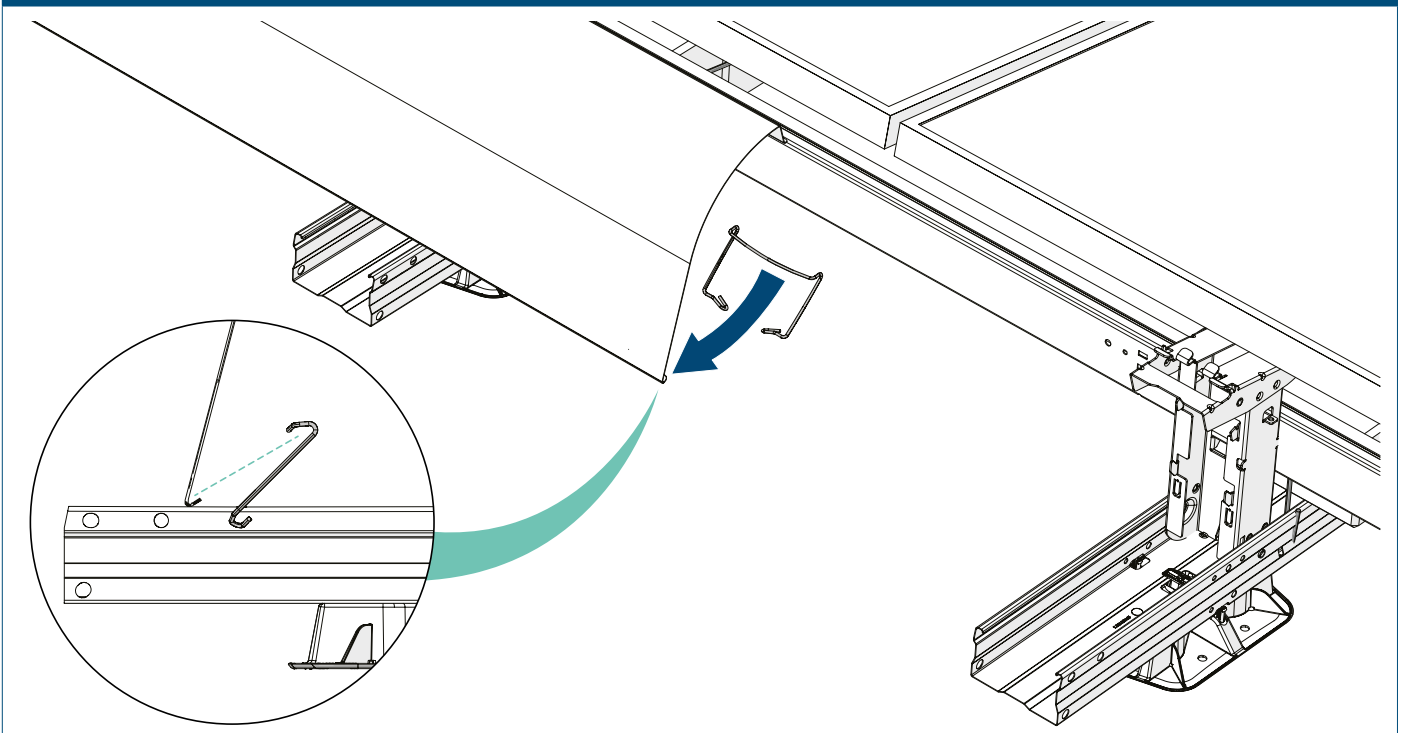

6 Slide the rear deflector clip over the edge until the rear deflector clip rests on the unit.

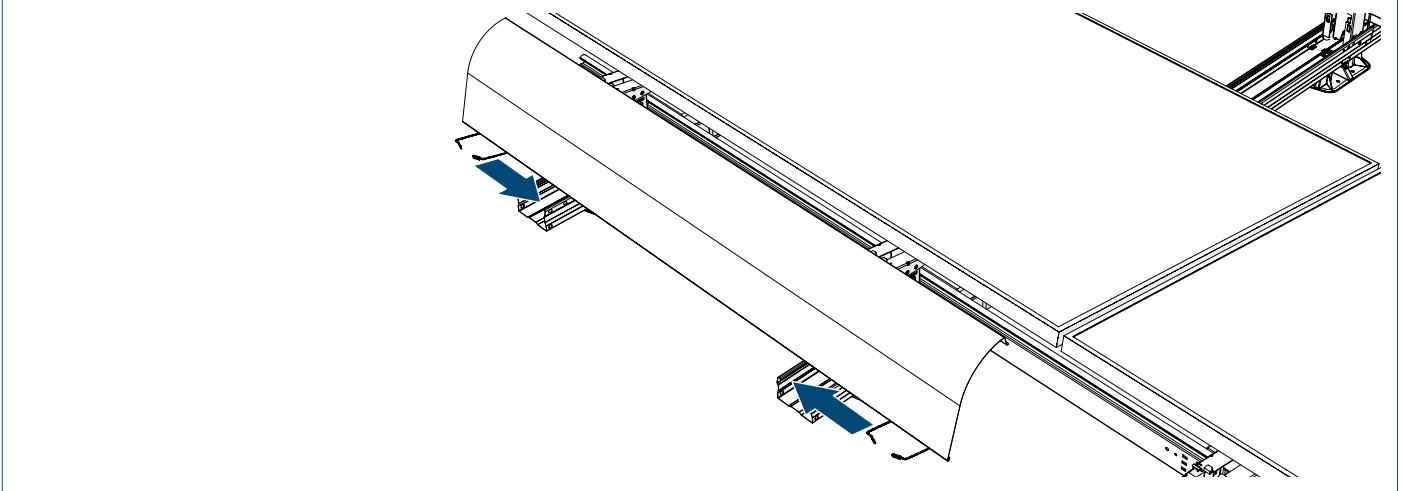

7 Bend the rear deflector clip outwards and clamp the rear deflector clip around the unit.

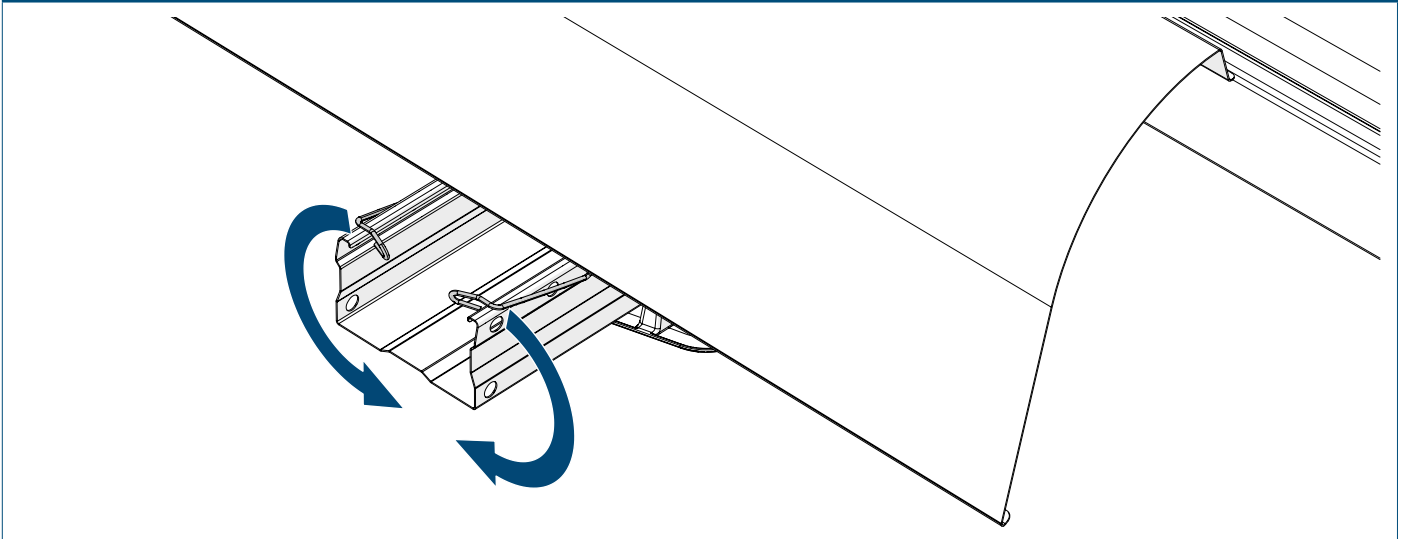

Repeat the steps in this chapter for all wind deflectors.

When the rear deflectors are properly aligned, there will be space between two rear deflectors. The rear deflectors are then correctly mounted.

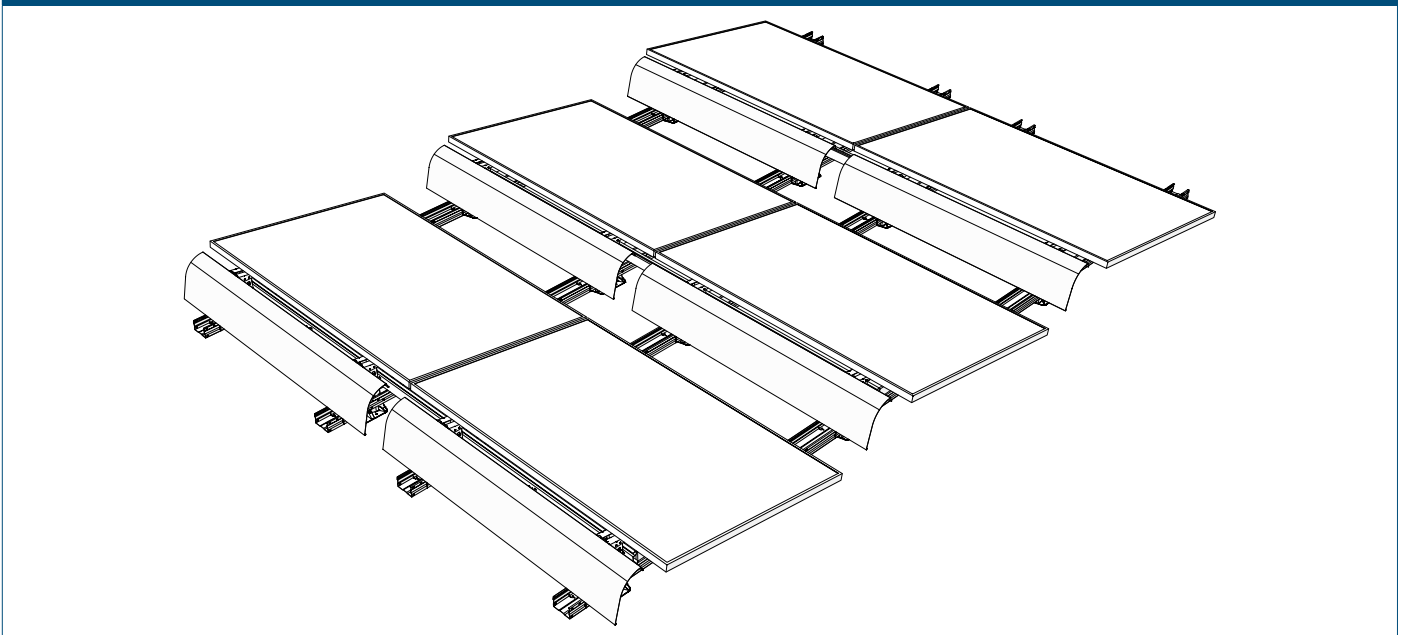



Annexes

A. Cable management

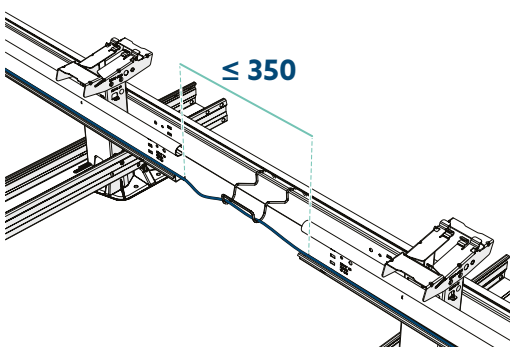
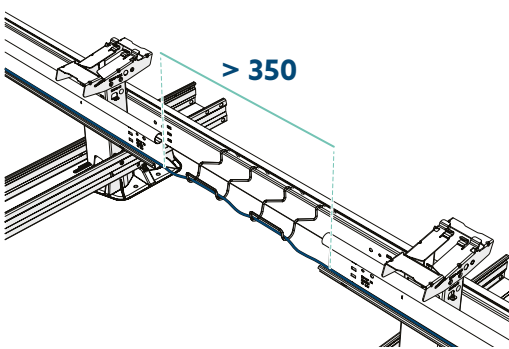
Cable bracket positioning table

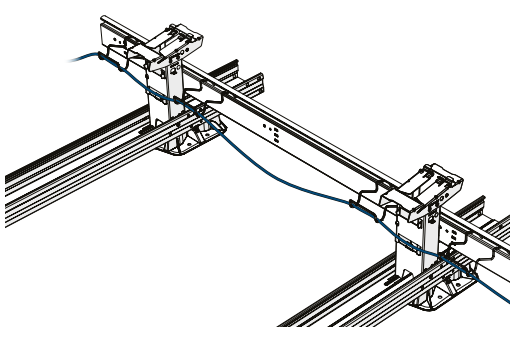
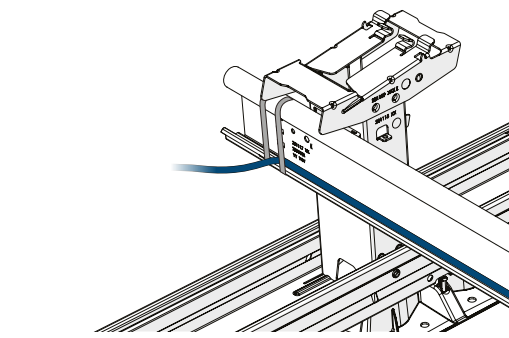
	Spacing ≤ 350 mm	Spacing > 350 mm
		
Number of cable brackets	1	2
Positioning of the cable bracket	in the middle between the two stabilizers	2× 10 cm next to the two stabilizers
Fixing of the cable	Cable ties	Cable ties

	End of a row without stabilizer	End of a row with stabilizer
		
Number of cable brackets	3	0
Positioning of the cable bracket	1× 10 cm next to the end of the stabilizer 2× 5 cm next to the high base	 Do not lay the cable over the end of the stabilizers: sharp edges can damage the cable.
Fixing of the cable	Cable ties	Cable ties

B. Grounding and equipotential bonding

Method for grounding/equipotential bonding

Thanks to the integrated part bonding, no additional equipotential bonding between the metal parts is required:

- 1) Fully tightening the panel clamping ensures the correct contact of the panel frame with the high base
- 2) The cutting edge at the top of the uprights cut into the frame edge of the solar panels.
- 3) The cutting edge at the bottom of the high base elements cuts into the module frame of the solar panel.

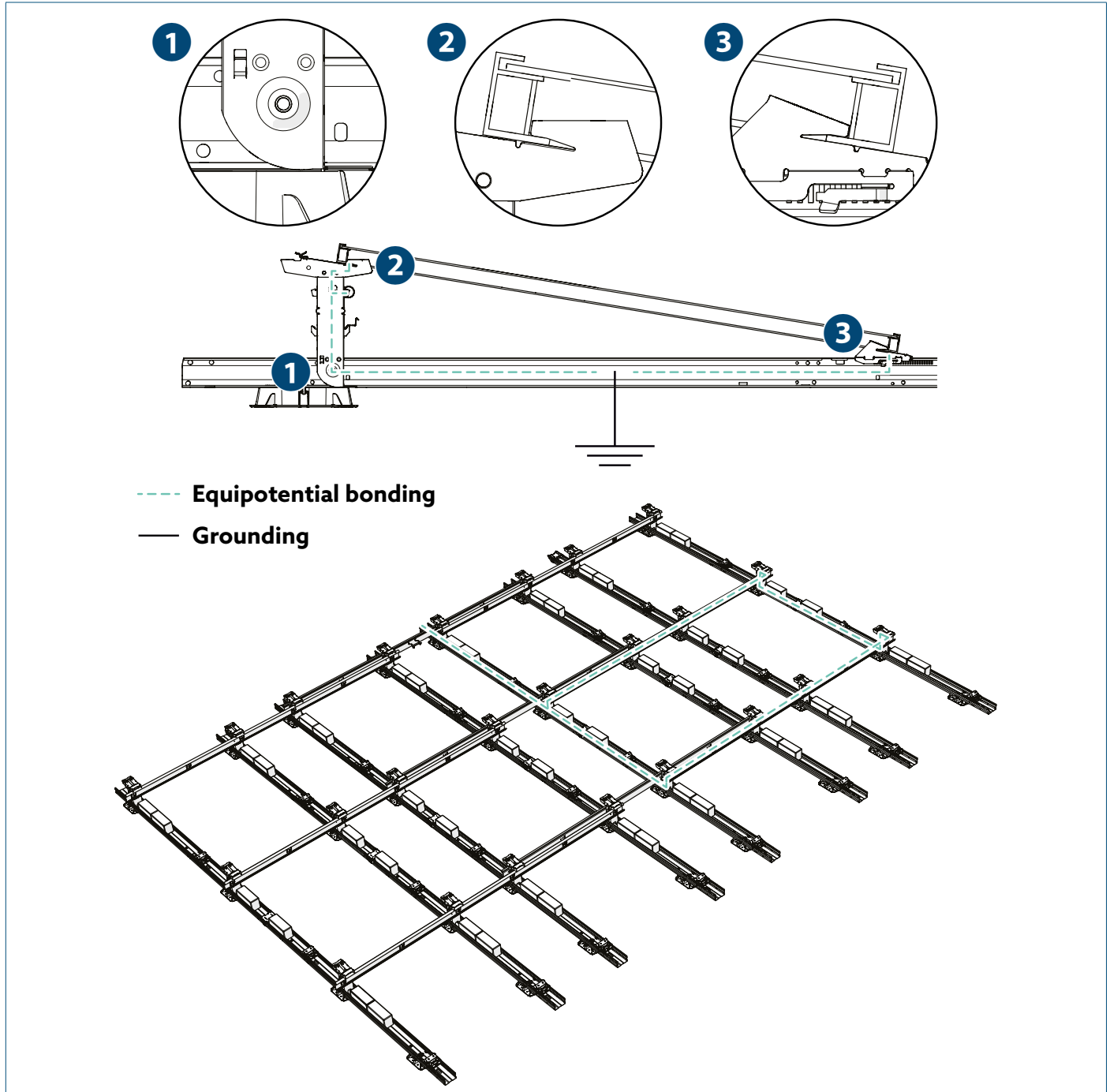

Installation of equipotential bonding conductor

- The earthing conductor ($\geq \varnothing 4\text{mm}^2$) runs parallel to the plus and min. conductors and is connected to a separate earthing point of the inverter.
- Each individual PV field will have its own bonding conductor.
- At least one unit in a field must be connected to an earth rail.
- The earthing cable can be fitted with a cable eye and screwed to the rail together with serrated spring washers.
- Correct installation: protected against corrosion and firmly assembled.

C. Removal and recycling

General

Always follow local laws and regulations when dismantling the mounting system and disposing of it.

Removing coupler

6 Remove the coupler from the first row of units if it is in the way

i Couplers can not be re-used after removal.

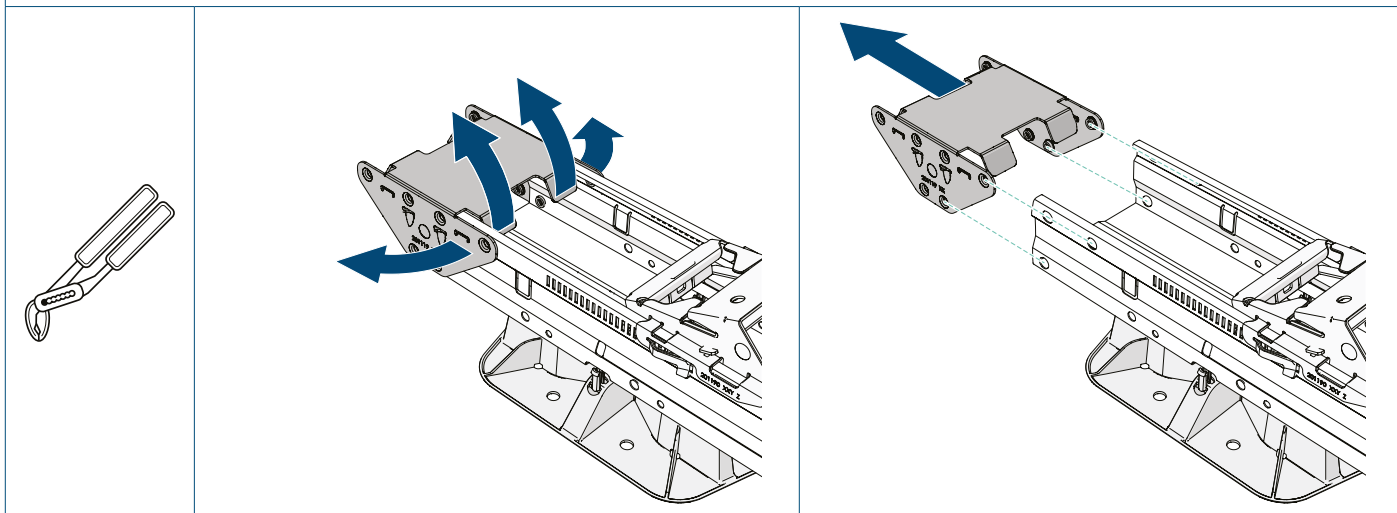

Removing a solar panel

- 1 Unlock the panel clamp using a small flathead screwdriver.
- 2 Slide the panel clamp back using the module unlock tool.
- 3 Lift the front of the solar panel 2 to 3 cm and push it back to slide the solar panel out of the high bases.

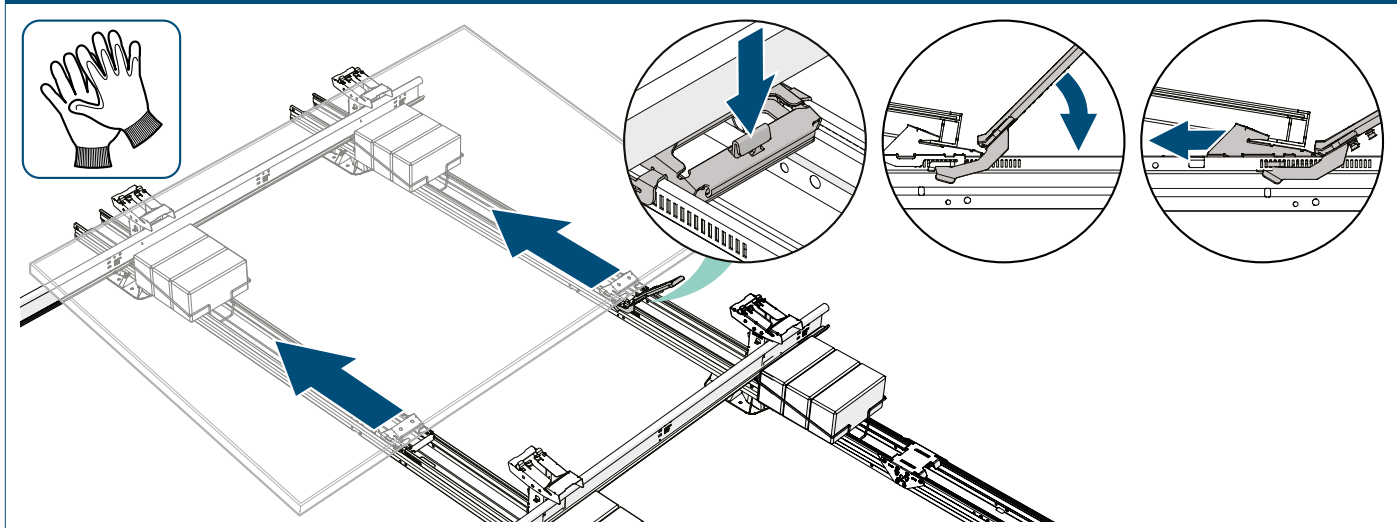



www.panelclaw.eu